

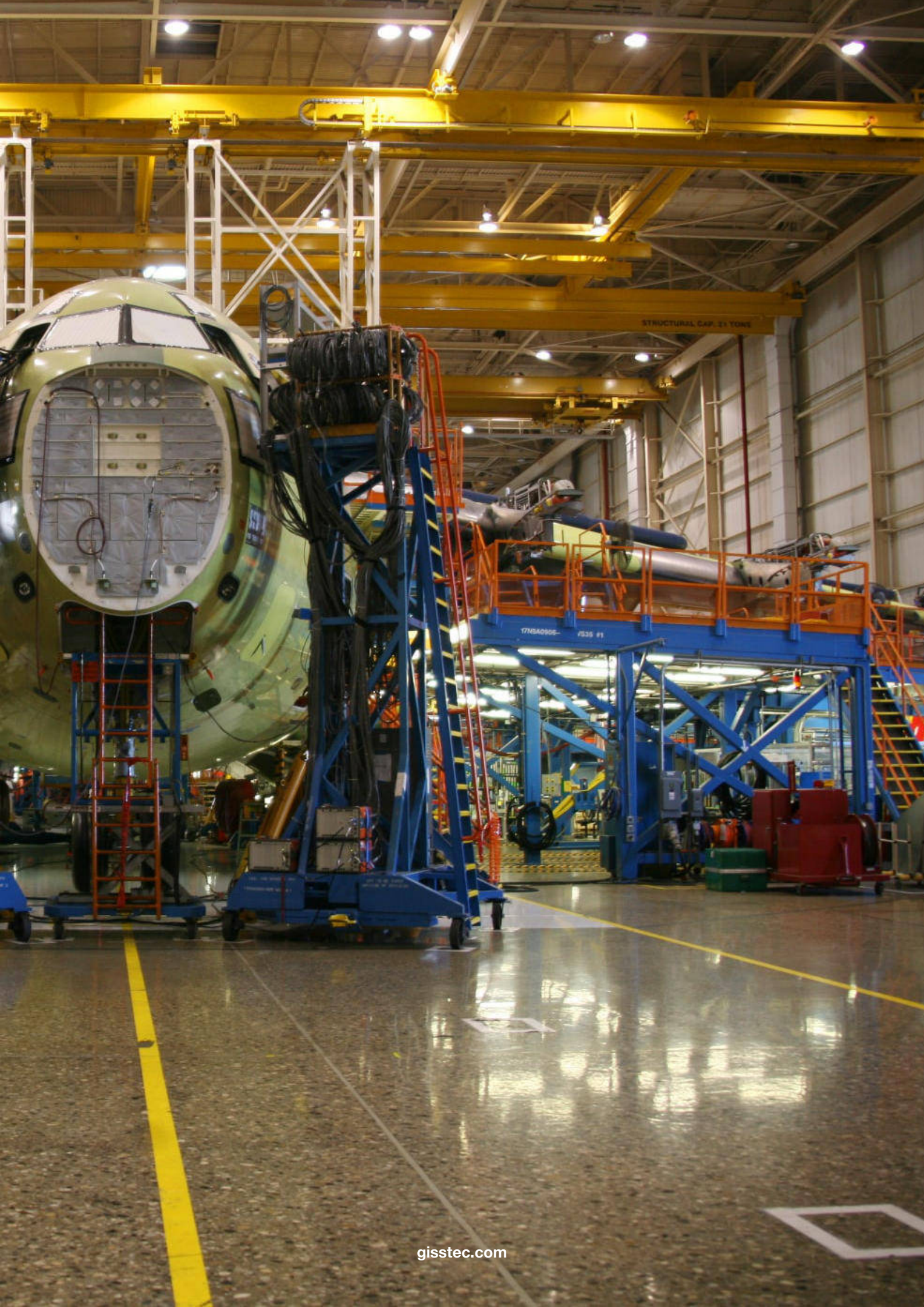

WINKELKÖPFE | MEHRSPINDELKÖPFE
ANGLE HEADS | MULTISPINDLE HEADS



MOTION LINE

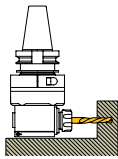
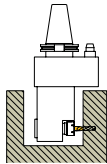
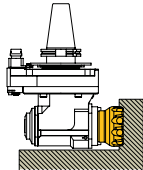
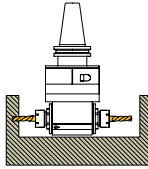
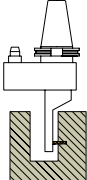
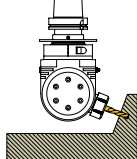
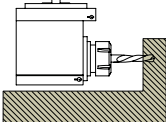

STRUCTURAL CAP. 2x TONS

17MSA0905- #335 #1

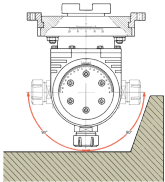
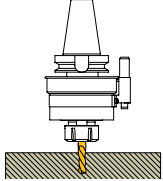
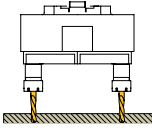
GA	90° Angle Head 90° Winkelkopf	6	
GA-L	90° Angle Head Extended 90° Winkelkopf Verlängert	10	
GA-X	90° Angle Head with ISO30/40 Output 90° Winkelkopf mit ISO30/40 -Ausführung	12	
GD	90° Double Output Angle Head 90° Doppel-Winkelkopf	13	
GS	90° Slim Angle Head 90° Winkelkopf, schmale Bauform	16	
GT	Tilting Head Schwenkkopf	20	
GA-F	90° Angle Head with Flange Connection 90° Winkelkopf mit Flanschverbindung	42	

GT-FX	Tilting Head With Flange Connection - GT-FX Series Schwenkkopf mit Flanschverbindung - GT-FX Serie	47	
SC	Spindle Speeder Schnelllaufspindel	49	
MS	Adjustable Multispindle Head Verstellbarer Mehrspindelkopf	52	
	Technical Information Technische Informationen	56	

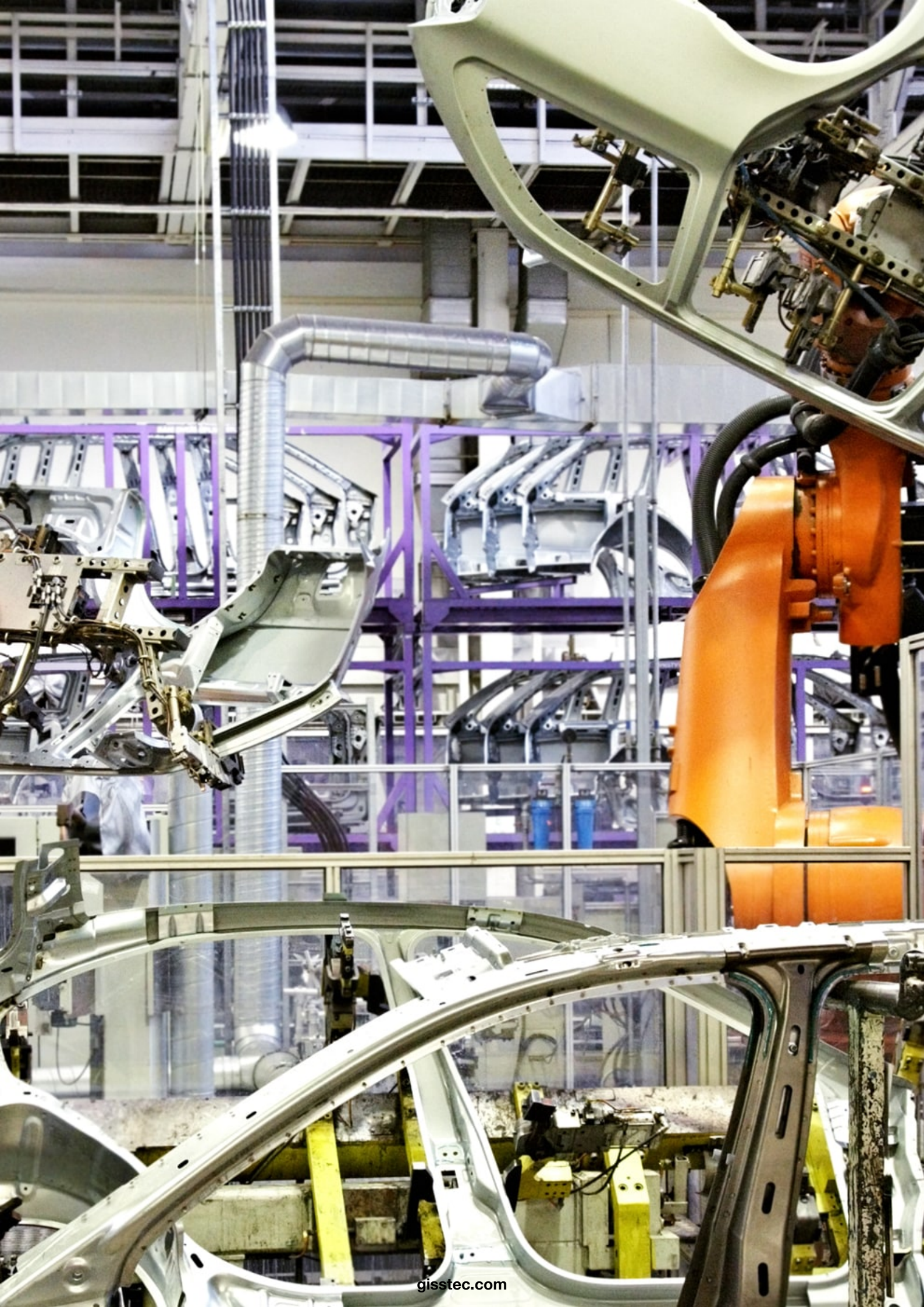



GA



GA-X



GA-L

Features

For drilling, tapping and milling operations
Usable on both CNC and conventional machine tools
Heat-treated aluminium or steel main body
Compact and rigid construction
Coolant feed through stop-bar pin
Orientation ring and stop-bar pin 360° rotatable

Merkmale

Bohren, gewindebohren und fräsen
Verwendbar mit CNC- und Universalfräsmaschinen
Gehäuse aus wärmebehandelter Aluminium- oder Stahllegierung
Kompakte und rigide Bauform
Kühlmittelzufuhr durch Anschlagstift
Skalenring und Anschlagstift können um 360° rotiert werden

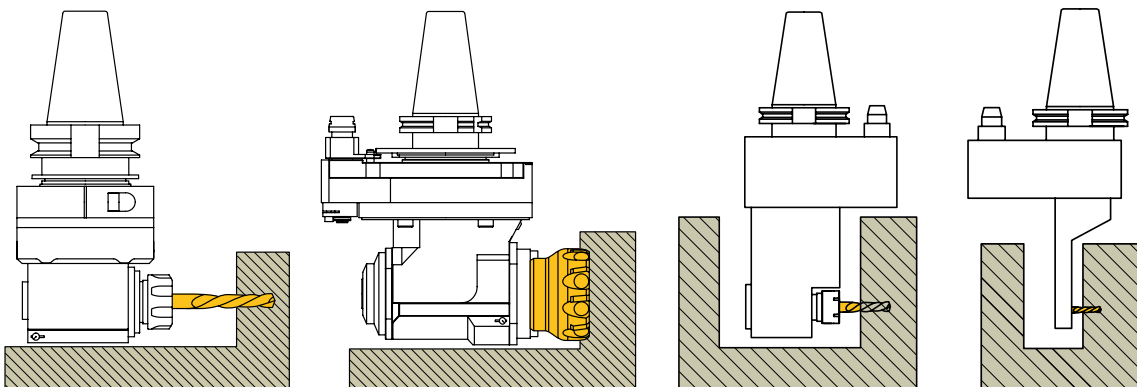

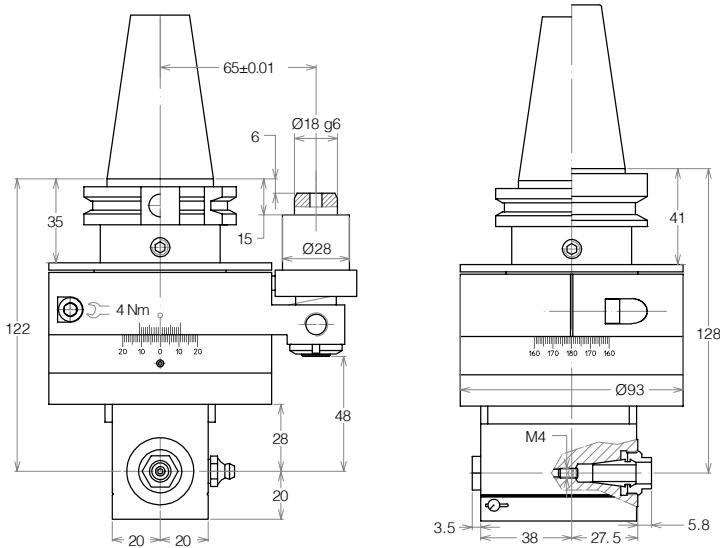

GA-11

SK40 / BT40 / CAT 40 / HSK63

ER11 **8.000 RPM** **13 Nm**

Schubkraft Thrust	Gewicht Weight	Übersetzung Ratio
----------------------	-------------------	----------------------

330 N 3,5 kg 1:1

Bohren
Drilling

Gewinde
Tapping

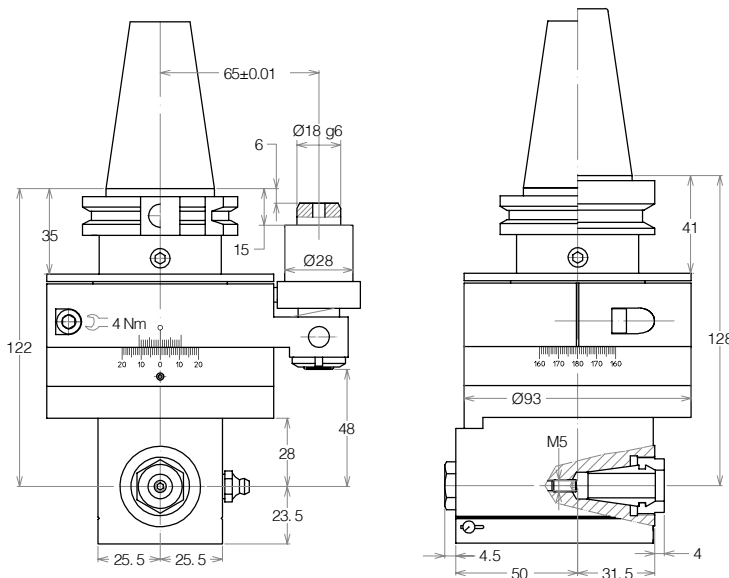
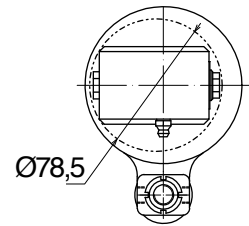

GA-16

SK40 / BT40 / CAT 40 / HSK63

ER16 **7.000 RPM** **27 Nm**

Schubkraft Thrust	Gewicht Weight	Übersetzung Ratio
----------------------	-------------------	----------------------

450 N 4 kg 1:1

Bohren
Drilling

Gewinde
Tapping

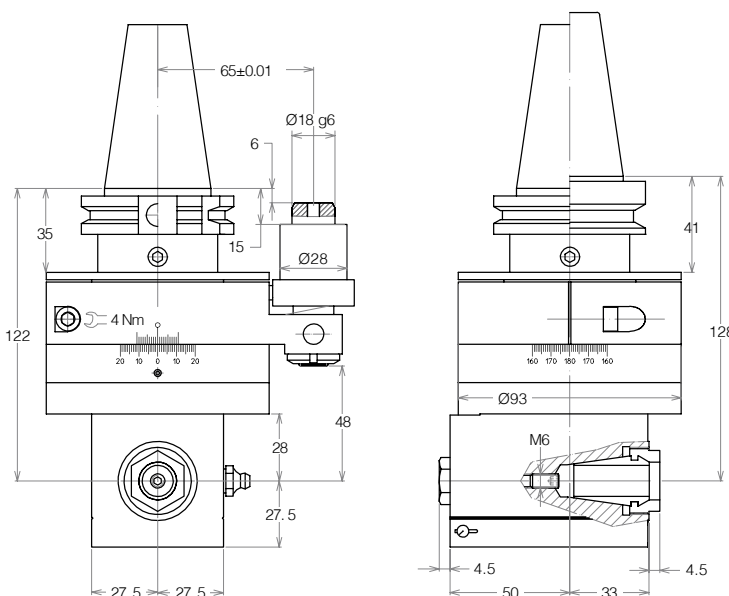
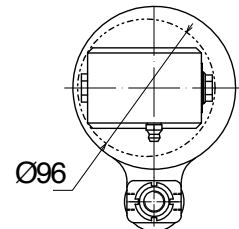

GA-20

SK40 / BT40 / CAT 40 / HSK63

ER20 **7.000 RPM** **27 Nm**

Schubkraft Thrust	Gewicht Weight	Übersetzung Ratio
----------------------	-------------------	----------------------

450 N 4,1 kg 1:1

Bohren
Drilling

Gewinde
Tapping

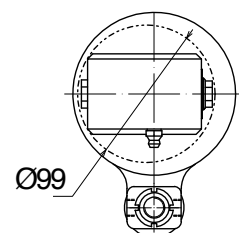

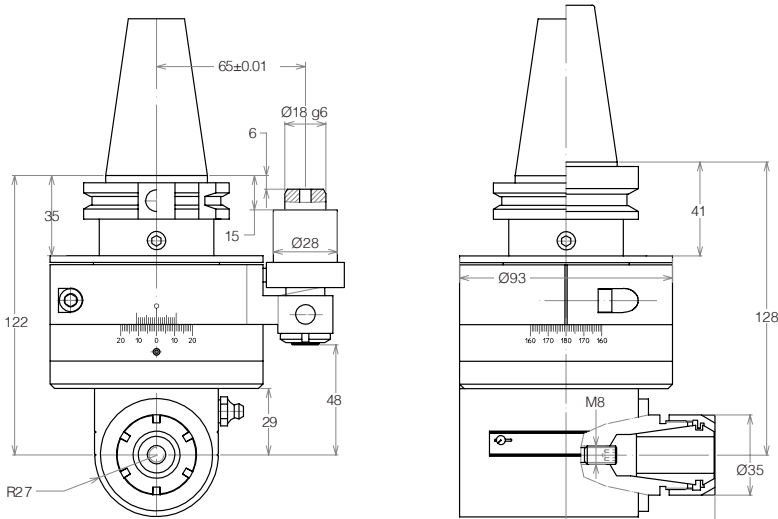

GA-25

SK40 / BT40 / CAT 40 / HSK63

ER25	6.000 RPM	30 Nm
------	-----------	-------

Schubkraft Thrust	Gewicht Weight	Übersetzung Ratio
450 N	4,5 kg	1:1

- Bohren
Drilling Ø16
- Gewinde
Tapping M12

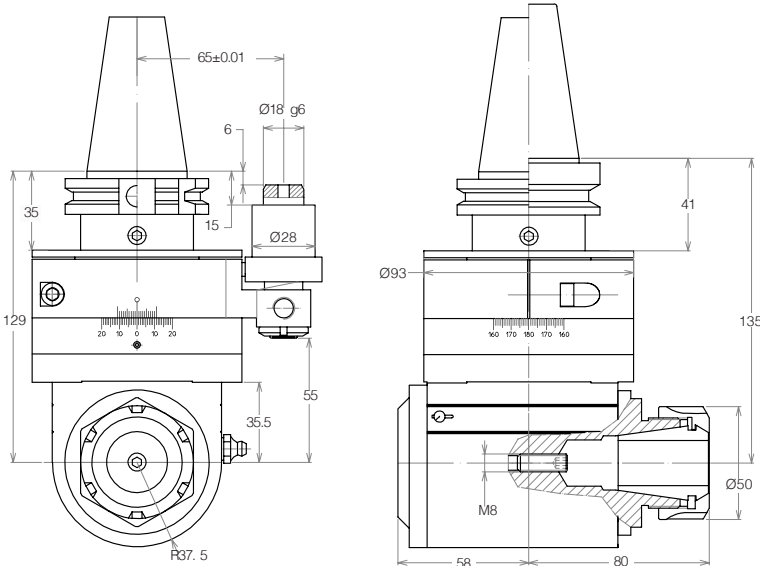
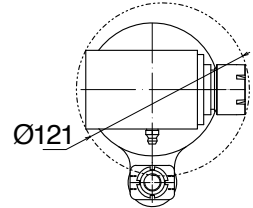

GA-32

SK40 / BT40 / CAT 40 / HSK63

ER32	4.000 RPM	66 Nm
------	-----------	-------

Schubkraft Thrust	Gewicht Weight	Übersetzung Ratio
1200 N	7 kg	1:1

- Bohren
Drilling Ø20
- Gewinde
Tapping M16

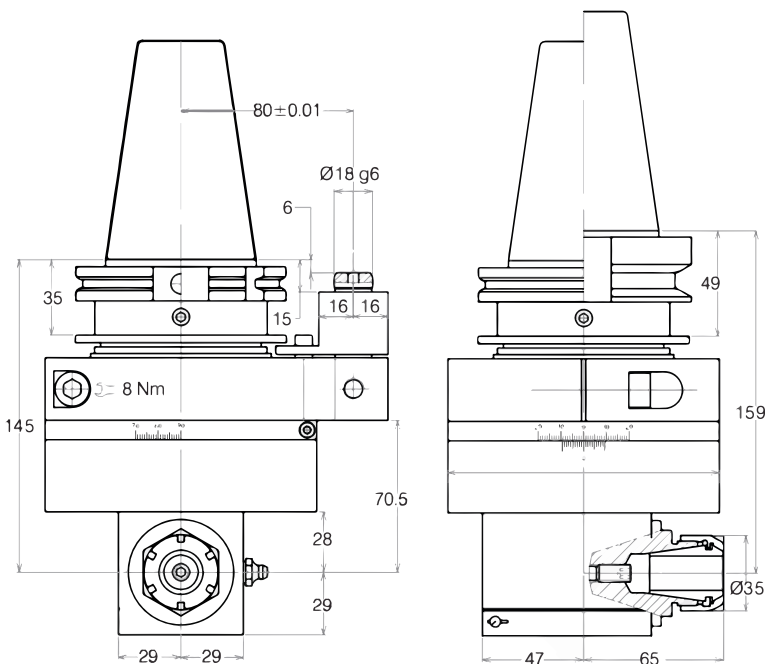
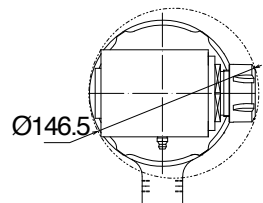

GA-25

SK50 / BT50 / CAT 50 / HSK100

ER25	6.000 RPM	30 Nm
------	-----------	-------

Schubkraft Thrust	Gewicht Weight	Übersetzung Ratio
1000 N	9,2 kg	1:1

- Bohren
Drilling Ø16
- Gewinde
Tapping M12

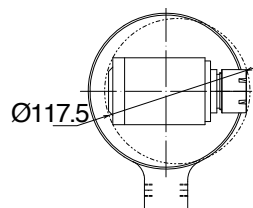

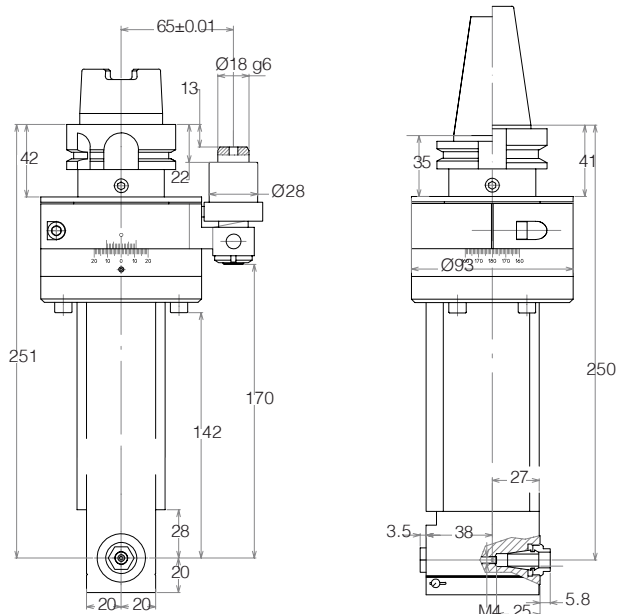

GA-L11

SK40 / BT40 / CAT 40 / HSK63

ER11 **8.000 RPM** **13 Nm**

Schubkraft Thrust	Gewicht Weight	Übersetzung Ratio
180 N	4,9 kg	1:1

- Bohren
Drilling
- Gewinde
Tapping

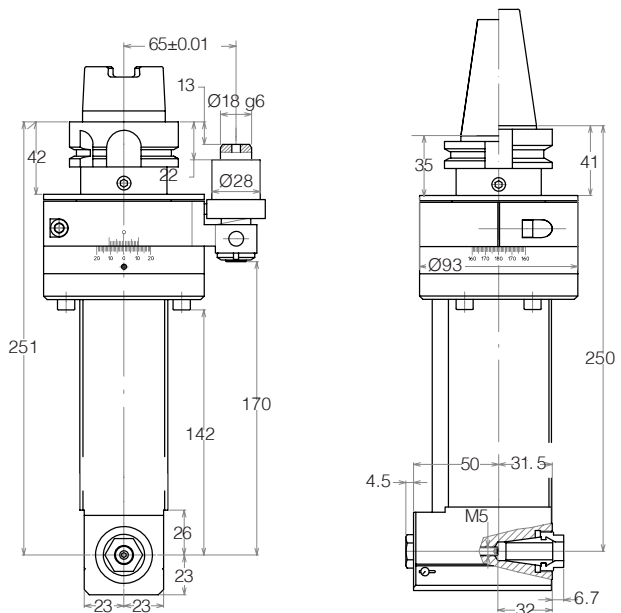
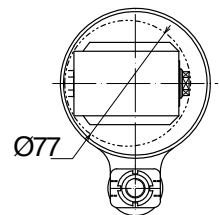

GA-L16

SK40 / BT40 / CAT 40 / HSK63

ER16 **7.000 RPM** **27 Nm**

Schubkraft Thrust	Gewicht Weight	Übersetzung Ratio
180 N	5,5 kg	1:1

- Bohren
Drilling
- Gewinde
Tapping

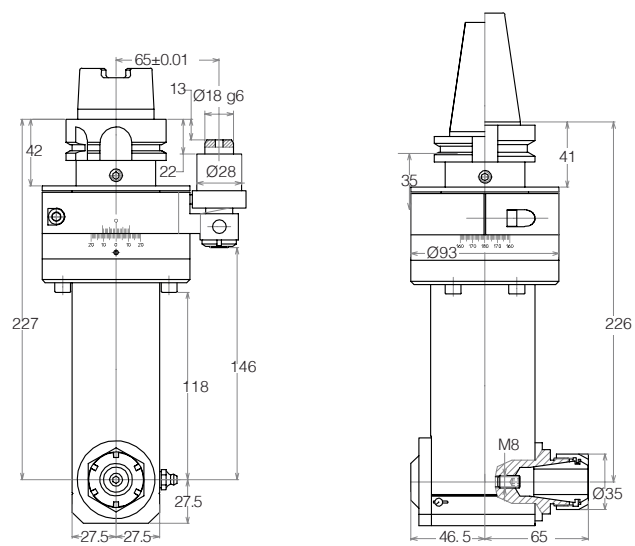
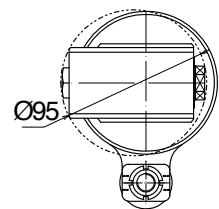

GA-L25

SK40 / BT40 / CAT 40 / HSK63

ER25 **6.000 RPM** **30 Nm**

Schubkraft Thrust	Gewicht Weight	Übersetzung Ratio
230 N	6,5 kg	1:1

- Bohren
Drilling
- Gewinde
Tapping

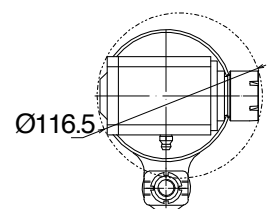

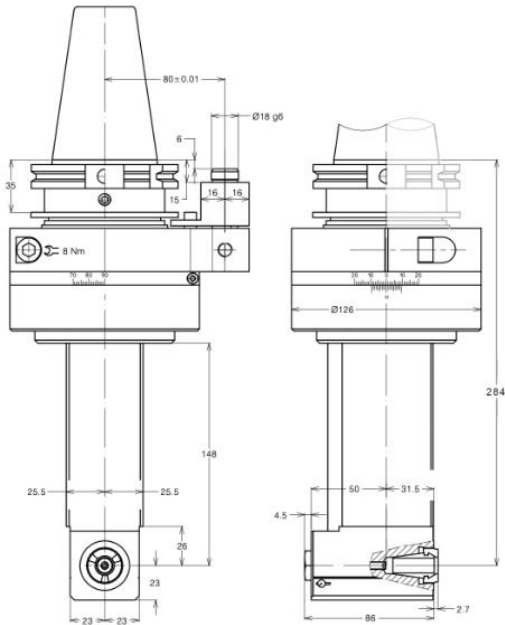

GA-L16

SK50 / BT50 / CAT 50 / HSK100

ER16	9.000 RPM	27 Nm
------	-----------	-------

Schubkraft Thrust	Gewicht Weight	Übersetzung Ratio
400 N	9,5 kg	1:1

Bohren Drilling	Ø10
Gewinde Tapping	M8

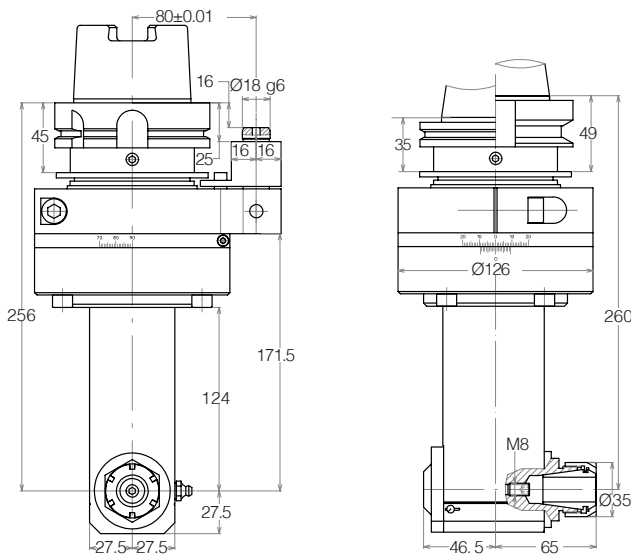
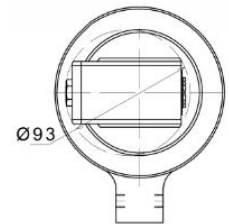

GA-L25

SK50 / BT50 / CAT 50 / HSK100

ER25	6.000 RPM	30 Nm
------	-----------	-------

Schubkraft Thrust	Gewicht Weight	Übersetzung Ratio
450 N	11,3 kg	1:1

Bohren Drilling	Ø16
Gewinde Tapping	M12

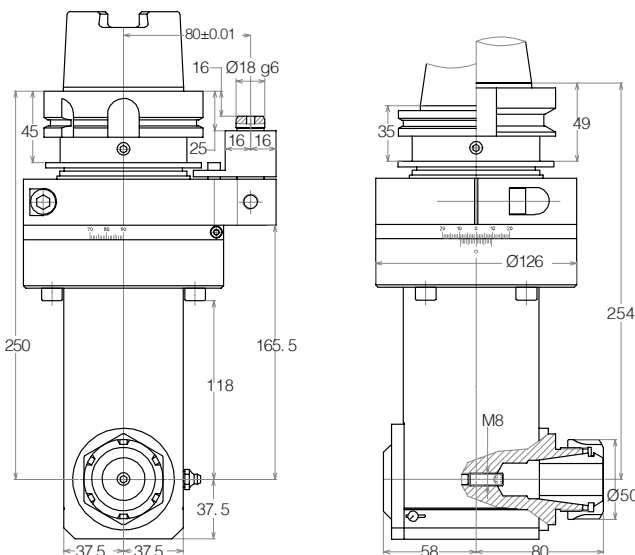
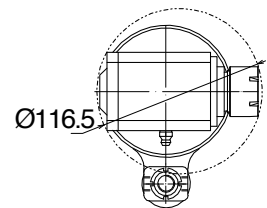

GA-L32

SK50 / BT50 / CAT 50 / HSK100

ER32	4.000 RPM	66 Nm
------	-----------	-------

Schubkraft Thrust	Gewicht Weight	Übersetzung Ratio
450 N	15,7 kg	1:1

Bohren Drilling	Ø20
Gewinde Tapping	M16

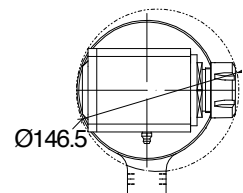

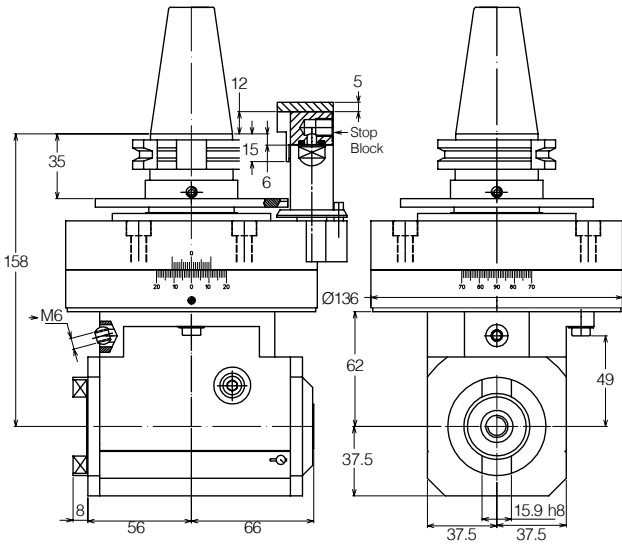

GA-X30

SK40 / BT40 / CAT 40 / HSK63

ISO30	3.500 RPM	40 Nm
-------	-----------	-------

Schubkraft Thrust	Gewicht Weight	Übersetzung Ratio
----------------------	-------------------	----------------------

750 N 7,4 kg 1:1

Bohren Drilling	Ø20
Gewinde Tapping	M16

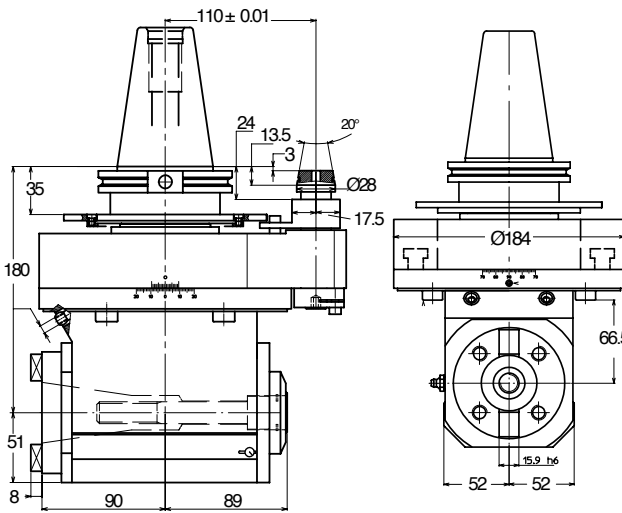
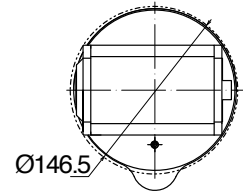

GA-X40

SK50 / BT50 / CAT 50 / HSK100

ISO40	4.000 RPM	110 Nm
-------	-----------	--------

Schubkraft Thrust	Gewicht Weight	Übersetzung Ratio
----------------------	-------------------	----------------------

1250 N 22,5 kg 1:1

Bohren Drilling	Ø26
Gewinde Tapping	M20

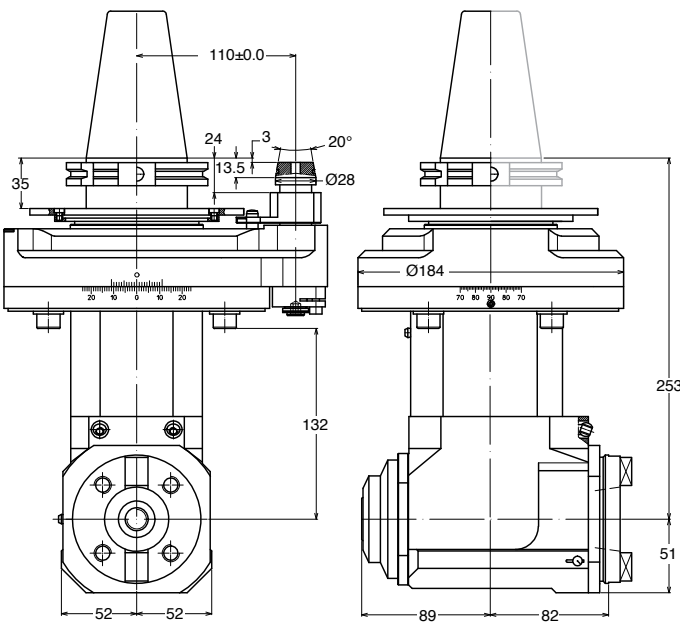
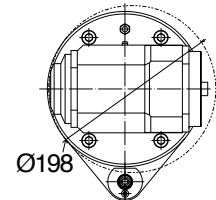

GA-X40L

SK50 / BT50 / CAT 50 / HSK100

ISO40	3.000 RPM	110 Nm
-------	-----------	--------

Schubkraft Thrust	Gewicht Weight	Übersetzung Ratio
----------------------	-------------------	----------------------

800 N 26,5 kg 1:1

Bohren Drilling	Ø26
Gewinde Tapping	M20

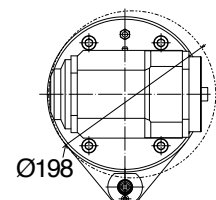

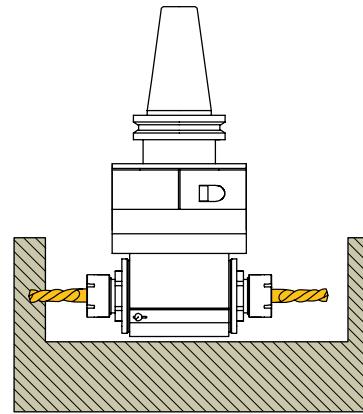

Features

- For drilling, tapping and milling operations
- Two opposing spindles
- Usable on both CNC and conventional machine tools
- Heat-treated aluminium or steel main body
- Coolant feed through stop-bar pin
- Orientation ring and stop-bar pin 360° rotatable

Merkmale

- Bohren, Gewindebohren, Fräsen
- Doppelspindlig
- Verwendbar mit CNC- und herkömmlichen Werkzeugmaschinen
- Hauptkörper aus wärmebehandelter Aluminium- oder Stahllegierung
- Kühlmittelzufuhr durch Anschlagstift
- Skalenring und Anschlagstift können um 360° rotiert werden

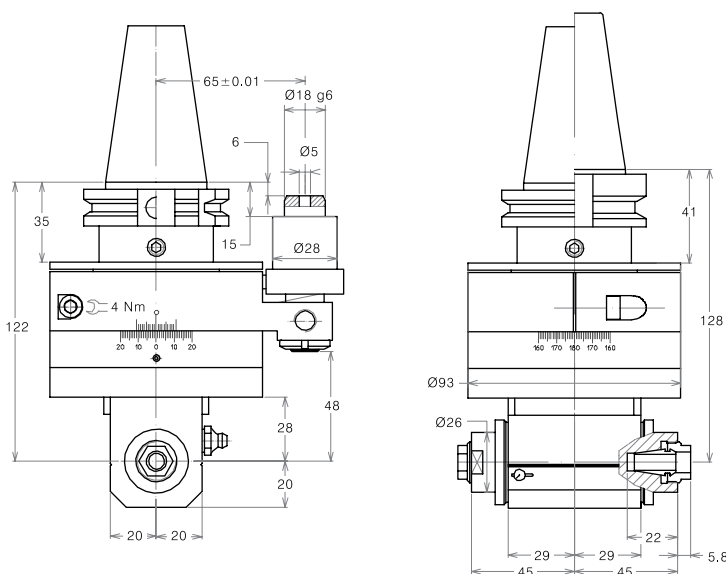

GD-11

SK40 / BT40 / CAT 40 / HSK63

ER11 **8.000 RPM** **13 Nm**

Schubkraft Thrust	Gewicht Weight	Übersetzung Ratio
330 N	4 kg	1:1

- Bohren Drilling
- Gewinde Tapping

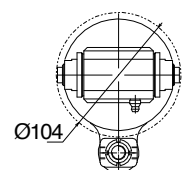

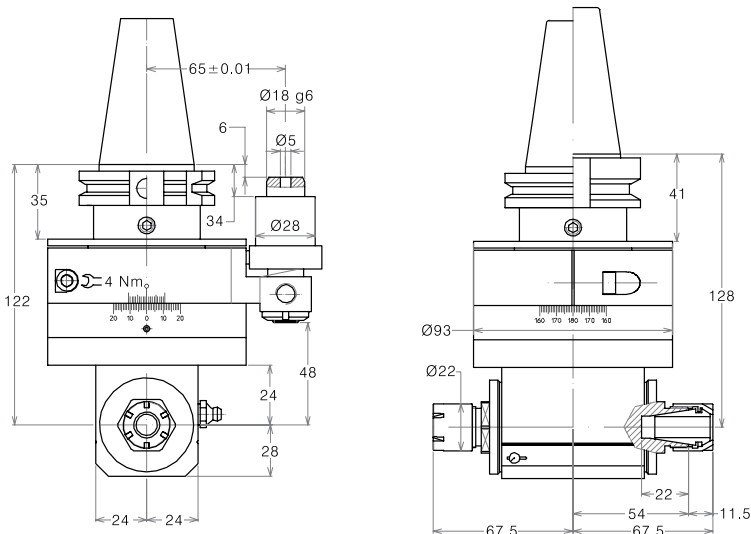

GD-16

SK40 / BT40 / CAT 40 / HSK63

ER16 **7.000 RPM** **27 Nm**

Schubkraft Thrust	Gewicht Weight	Übersetzung Ratio
450 N	5 kg	1:1

Bohren Drilling	Ø10
Gewinde Tapping	M8

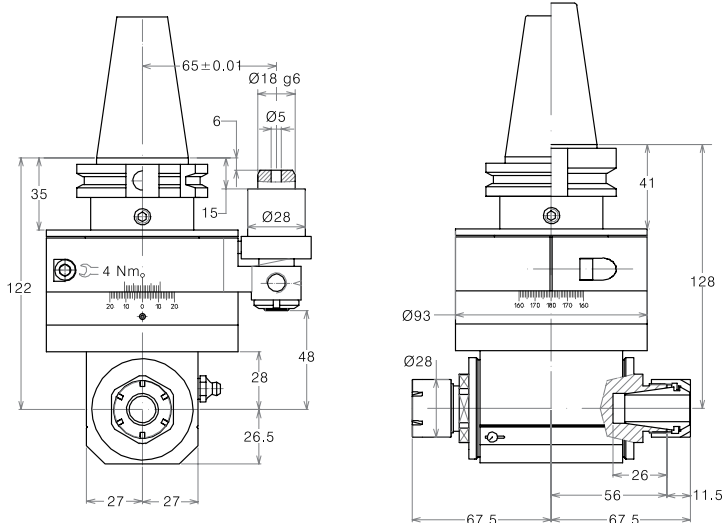
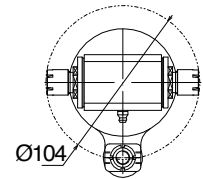

GD-20

SK40 / BT40 / CAT 40 / HSK63

ER20 **7.000 RPM** **27 Nm**

Schubkraft Thrust	Gewicht Weight	Übersetzung Ratio
450 N	5,1 kg	1:1

Bohren Drilling	Ø13
Gewinde Tapping	M10

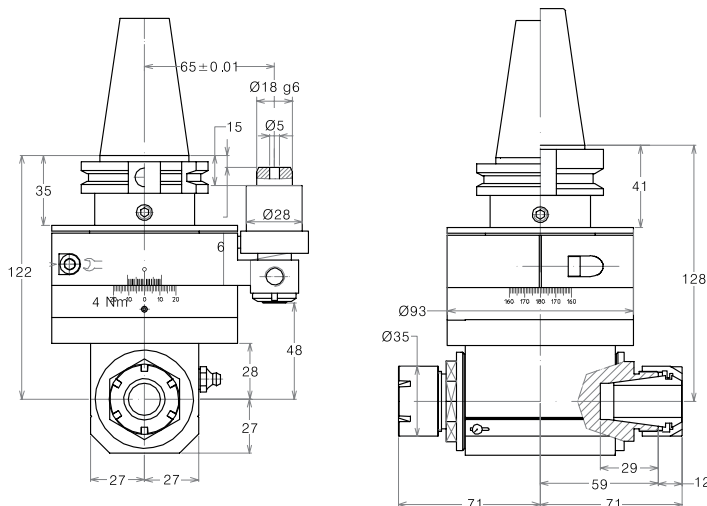
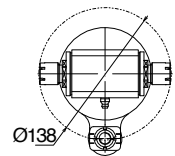

GD-25

SK40 / BT40 / CAT 40 / HSK63

ER25 **6.000 RPM** **30 Nm**

Schubkraft Thrust	Gewicht Weight	Übersetzung Ratio
450 N	5,5 kg	1:1

Bohren Drilling	Ø16
Gewinde Tapping	M12

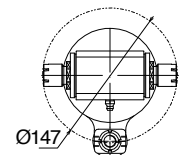

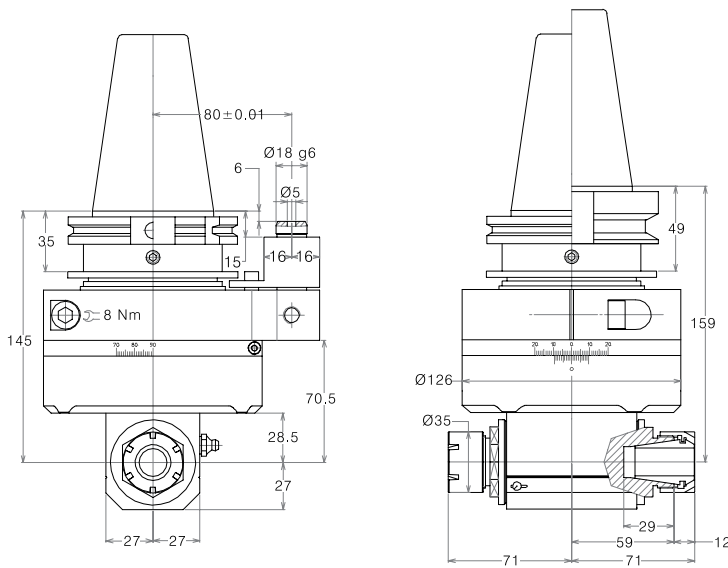

GD-25

SK50 / BT50 / CAT 50 / HSK100

ER25	6.000 RPM	30 Nm
------	-----------	-------

Schubkraft Thrust	Gewicht Weight	Übersetzung Ratio
850 N	11 kg	1:1

Bohren Drilling	Ø16
Gewinde Tapping	M12

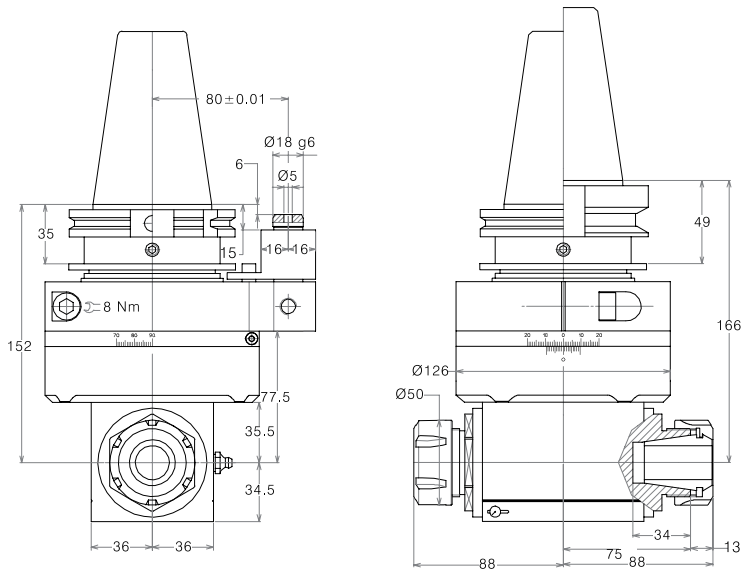
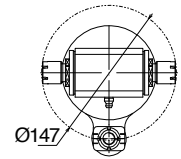

GD-32

SK50 / BT50 / CAT 50 / HSK100

ER32	4.000 RPM	66 Nm
------	-----------	-------

Schubkraft Thrust	Gewicht Weight	Übersetzung Ratio
1200 N	11,2 kg	1:1

Bohren Drilling	Ø20
Gewinde Tapping	M16

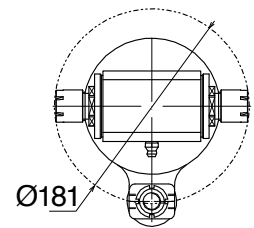



GS-3



GS-11

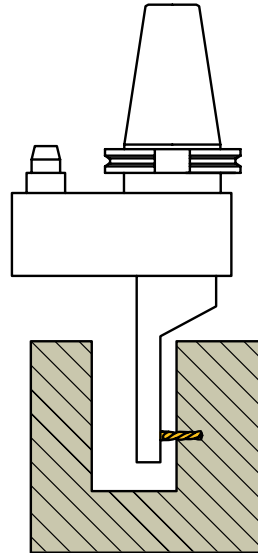

Features	Merkmale
<p>For drilling, tapping and light milling operations</p> <p>For cutting operations inside small bores</p> <p>Usable on both CNC and conventional machine tools</p> <p>Heat-treated aluminium or steel main body</p> <p>Compact and rigid construction</p> <p>Coolant feed through stop-bar pin</p>	<p>Für Bohrungen, Gewindebohren und leichte Fräsbearbeitungen</p> <p>Kleine Eintauchdurchmesser und große Eintauchtiefe</p> <p>Verwendbar mit CNC- und Universalwerkzeugmaschinen</p> <p>Gehäuse aus wärmebehandelter Aluminium- oder Stahllegierung</p> <p>Kompakte und rigide Bauform</p> <p>Kühlmittelezufuhr durch Anschlagstift</p>

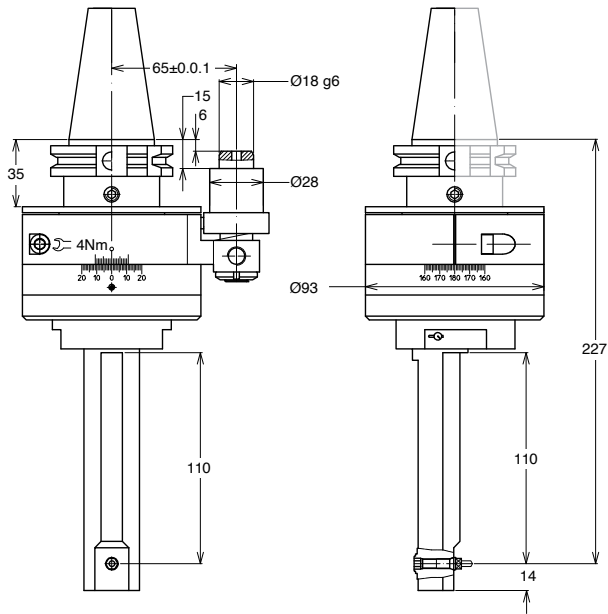

GS-3

SK40 / BT40 / CAT 40 / HSK163

6023E 8.000 RPM 4,5 Nm

Gewicht Weight Übersetzung Ratio

5 kg 1:1,1

Bohren Drilling

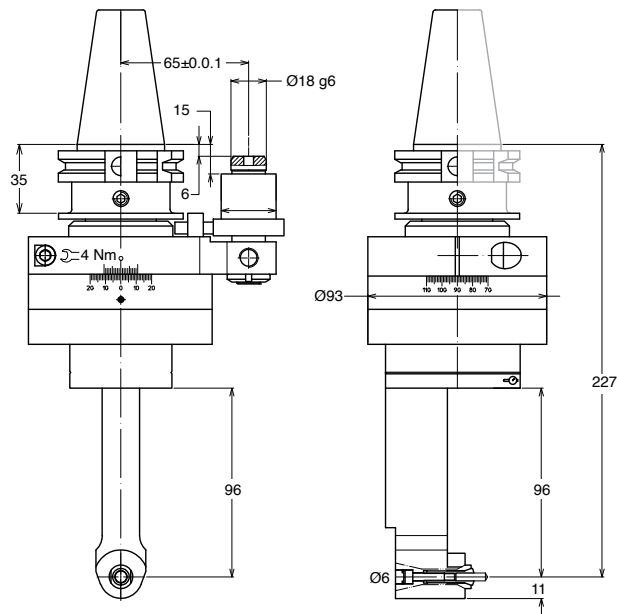
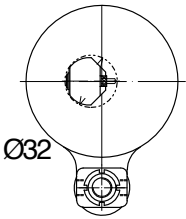

GS-6

SK40 / BT40 / CAT 40 / HSK163

P6-78-155 7.000 RPM 4,5 Nm

Gewicht Weight Übersetzung Ratio

5,1 kg 1:1

Bohren Drilling

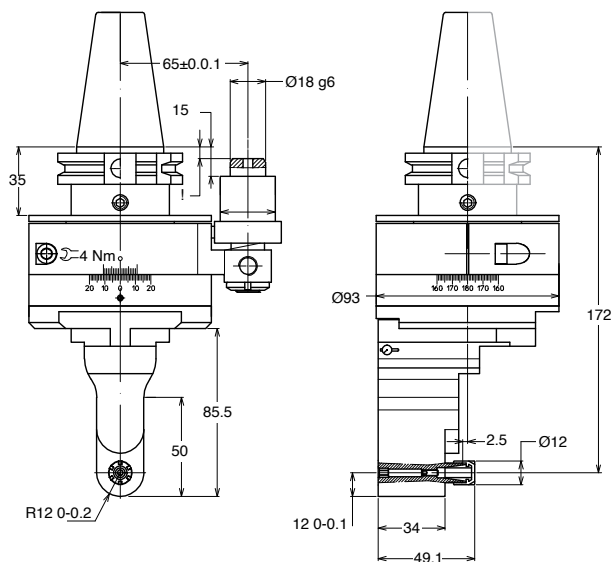
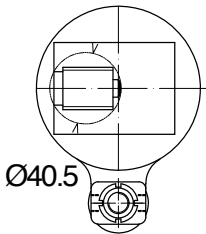

GS-8

SK40 / BT40 / CAT 40 / HSK163

ER8 10.000 RPM 12 Nm

Gewicht Weight Übersetzung Ratio

5,1 kg 1:1,5

Bohren Drilling

Gewinde Tapping

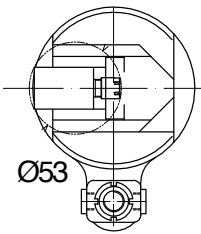

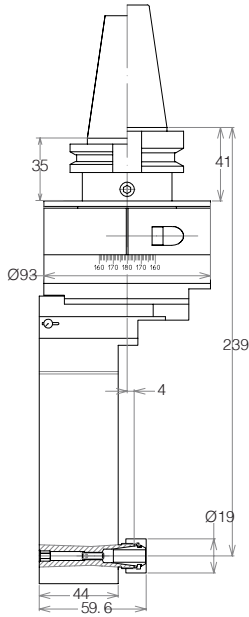
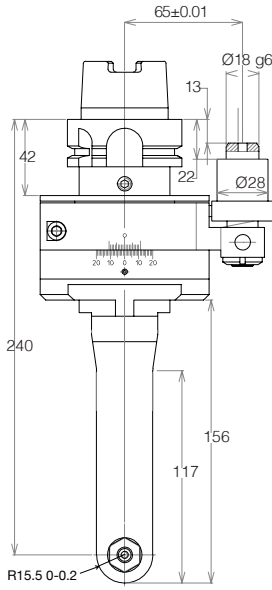

GS-11

SK40 / BT40 / CAT 40 / HSK63

ER11 7.000 RPM 12 Nm

Schubkraft Thrust	Gewicht Weight	Übersetzung Ratio
220 N	5 kg	1:1

- Bohren
Drilling
- Gewinde
Tapping

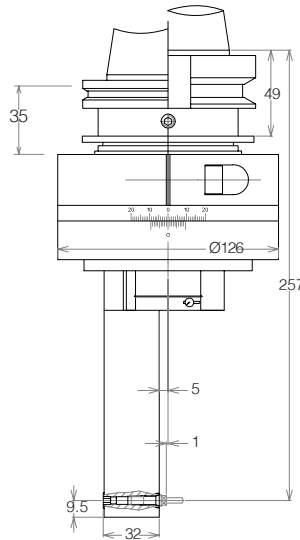
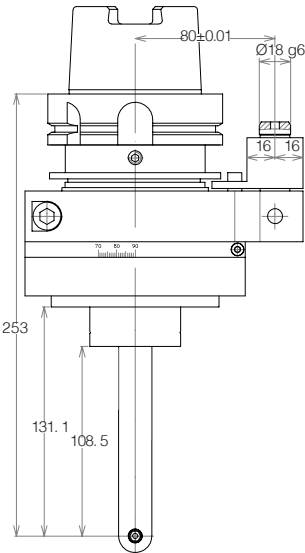
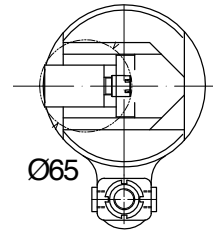

GS-3

SK50 / BT50 / CAT 50 / HSK100

6023e 8.000 RPM 4,5 Nm

Gewicht Weight	Übersetzung Ratio
10,5 kg	1:1,1

- Bohren
Drilling

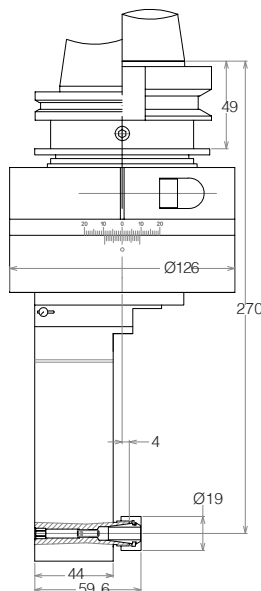
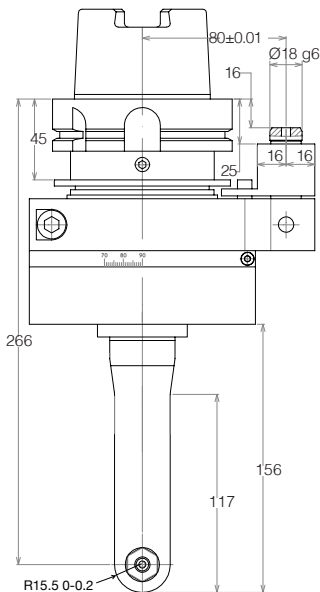
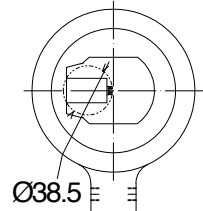

GS-11

SK50 / BT50 / CAT 50 / HSK100

ER11 7.000 RPM 12 Nm

Gewicht Weight	Übersetzung Ratio
10,5 kg	1:1

- Bohren
Drilling
- Gewinde
Tapping

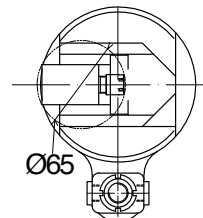

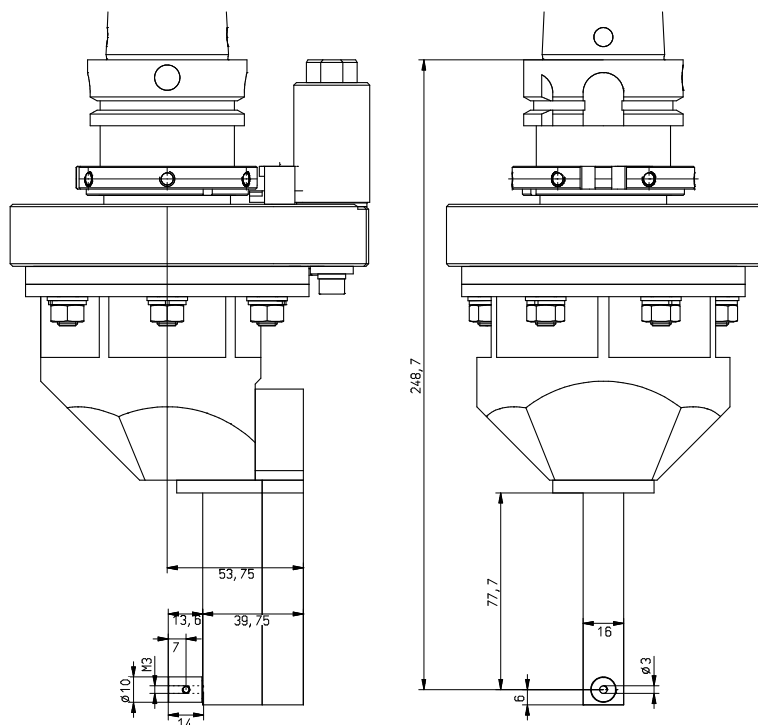

GS-3-6

SK40 / BT40 / CAT 40 / HSK63

Ø3 **18.000 RPM**

Gewicht Weight	Übersetzung Ratio
7,5 kg	1 : 4,96

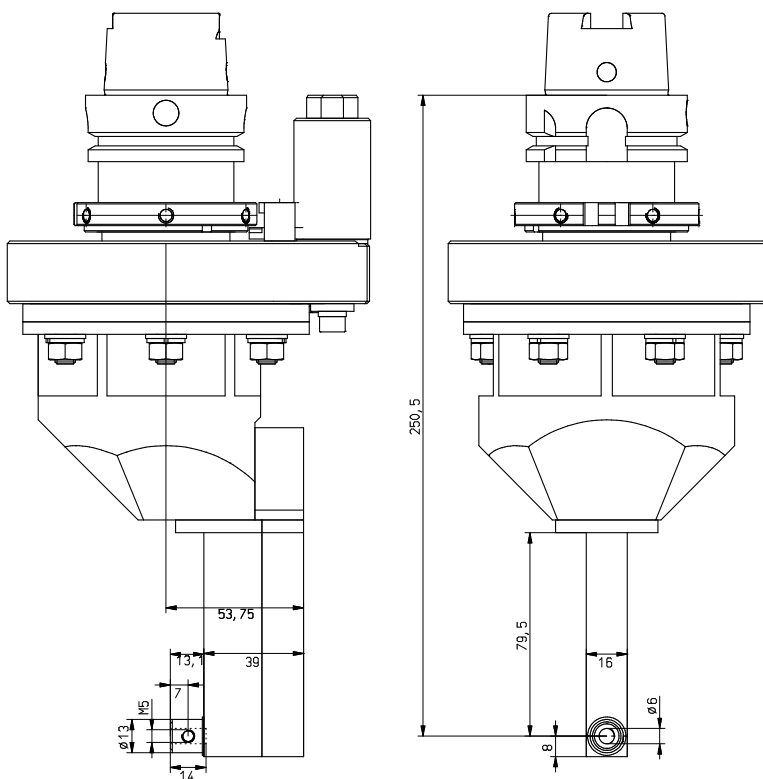

GS-6-8

SK40 / BT40 / CAT 40 / HSK63

Ø6 **18.000 RPM**

Gewicht Weight	Übersetzung Ratio
7,5 kg	1 : 4,96

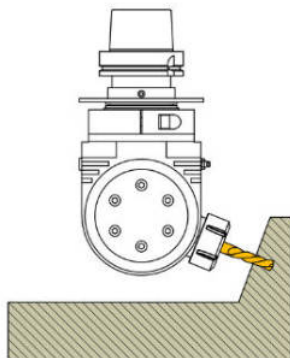

Features

- For drilling, tapping and light milling operations
- +/- 90° tilting spindle axis
- Usable on both CNC and conventional machine tools
- Heat-treated aluminium or steel main body
- Compact and rigid construction
- Coolant feed through stop-bar pin
- Orientation ring and stop-bar pin 360° rotatable

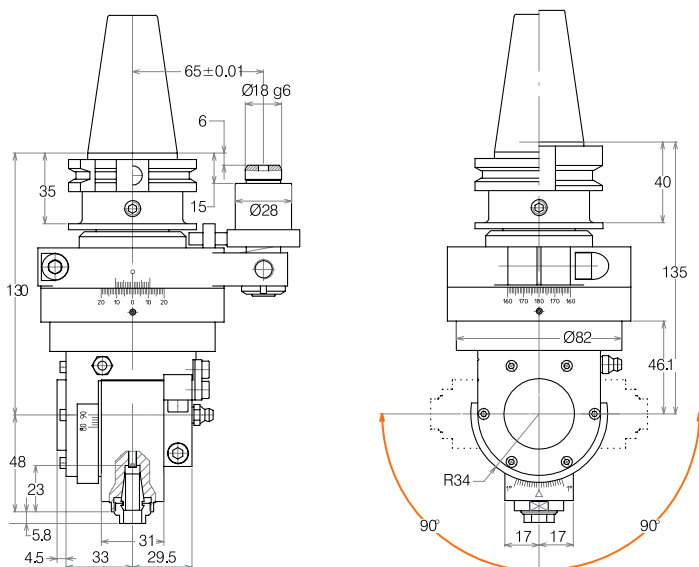

Merkmale

- Bohren, Gewindebohren und Fräsen
- +/- 90° verstellbarer Schwenkkopf
- Verwendbar mit CNC- und Universalwerkzeugmaschinen
- Hauptkörper aus wärmebehandelter Aluminiumlegierung
- Kompakte und rigide Bauform
- Kühlmittelezufuhr durch Anschlagstift
- Skalenring und Anschlagstift können um 360° rotiert werden



GT-11

SK40 / BT40 / CAT 40 / HSK63



ER11	12.000 RPM	5 Nm
Schubkraft Thrust	Gewicht Weight	Übersetzung Ratio
300 N	4,1 kg	1:1
Bohren Drilling		
Gewinde Tapping		

GT-16

SK40 / BT40 / CAT 40 / HSK63

ER16 **12.000 RPM** **12 Nm**

Schubkraft Thrust	Gewicht Weight	Übersetzung Ratio
350 N	4 kg	1:1

Bohren Drilling	
Gewinde Tapping	

GT-20

SK40 / BT40 / CAT 40 / HSK63

ER20 **12.000 RPM** **13 Nm**

Schubkraft Thrust	Gewicht Weight	Übersetzung Ratio
350 N	5 kg	1:1



Bohren Drilling	
Gewinde Tapping	

GT-25

SK40 / BT40 / CAT 40 / HSK63

ER25 **6.000 RPM** **14 Nm**

Schubkraft Thrust	Gewicht Weight	Übersetzung Ratio
500 N	5 kg	1:1

Bohren Drilling	
Gewinde Tapping	

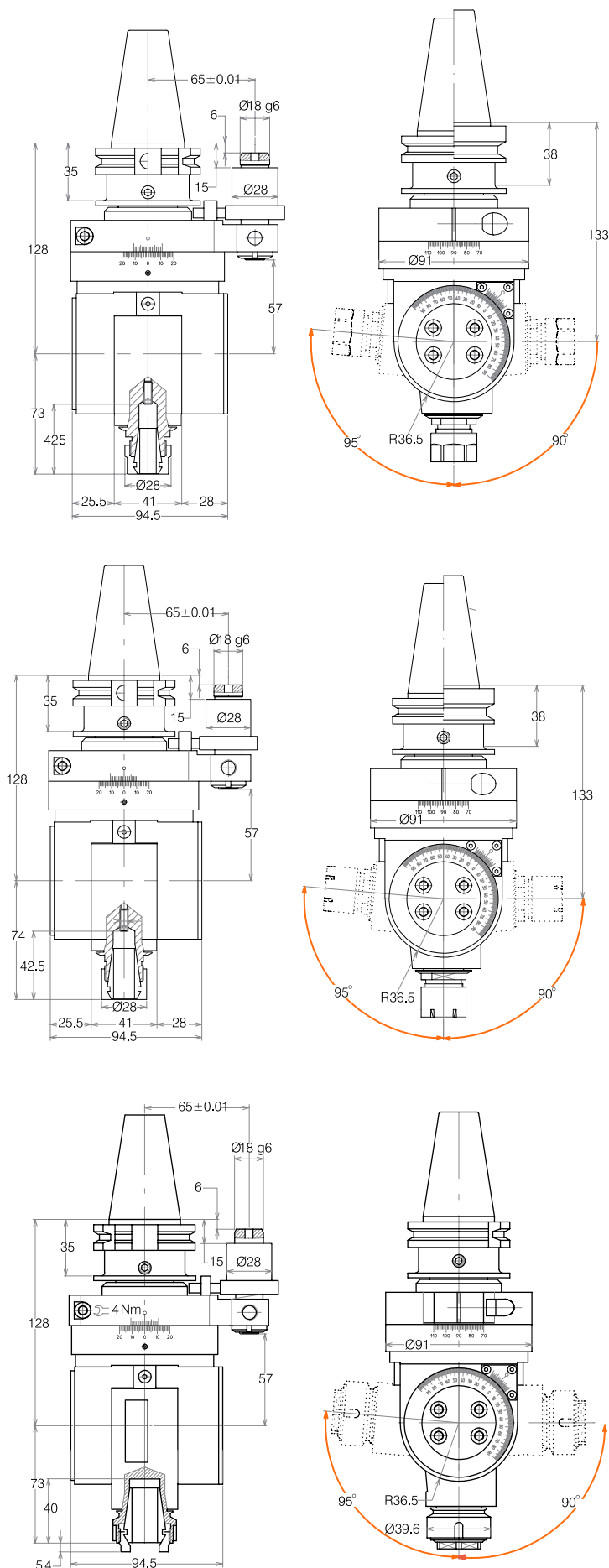
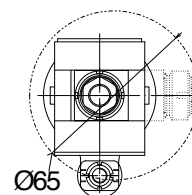

GT-25

SK50 / BT50 / CAT 50 / HSK100

ER25

6.000 RPM

27 Nm

Schubkraft
Thrust

Gewicht
Weight

Übersetzung
Ratio

1000 N

13 kg

1:1

Bohren
Drilling

Ø16

Gewinde
Tapping

M12

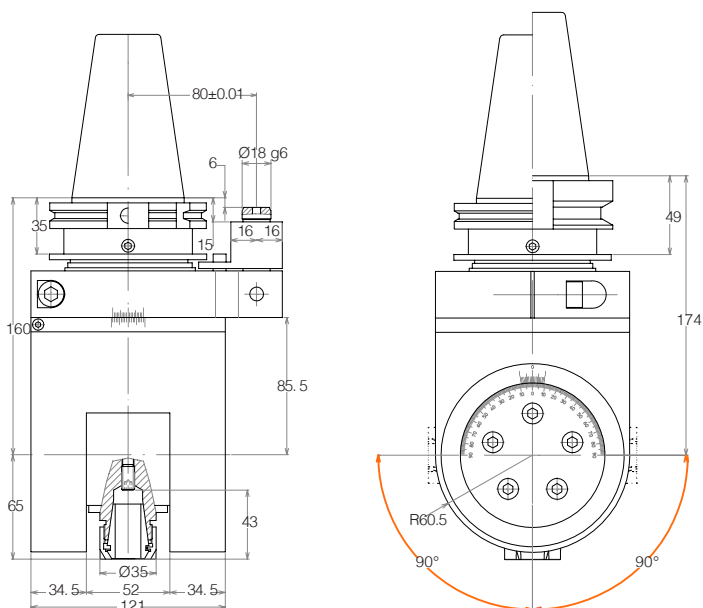

GT-32

SK50 / BT50 / CAT 50 / HSK100

ER32

5.000 RPM

50 Nm

Schubkraft
Thrust

Gewicht
Weight

Übersetzung
Ratio

1200 N

17 kg

1:1

Bohren
Drilling

Ø20

Gewinde
Tapping

M16

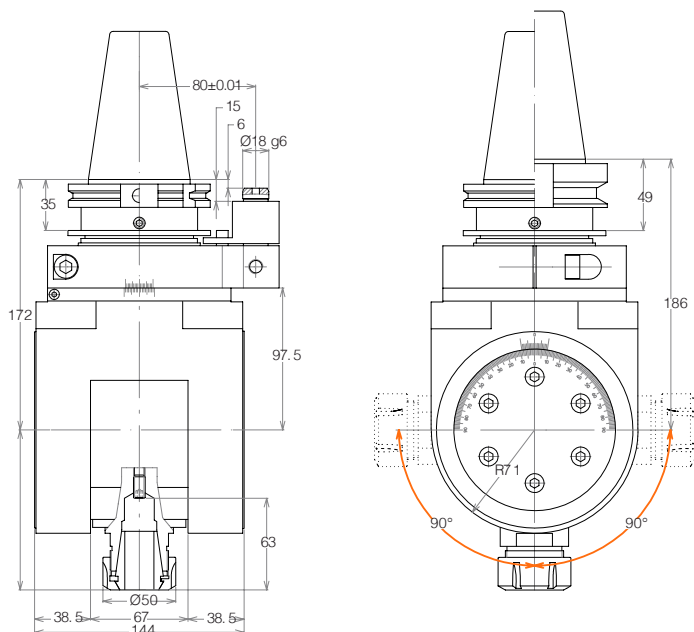

GT-40

SK50 / BT50 / CAT 50 / HSK100

ER40

3.500 RPM

55 Nm

Schubkraft
Thrust

Gewicht
Weight

Übersetzung
Ratio

1200 N

17 kg

1:1

Bohren
Drilling

Ø26

Gewinde
Tapping

M20

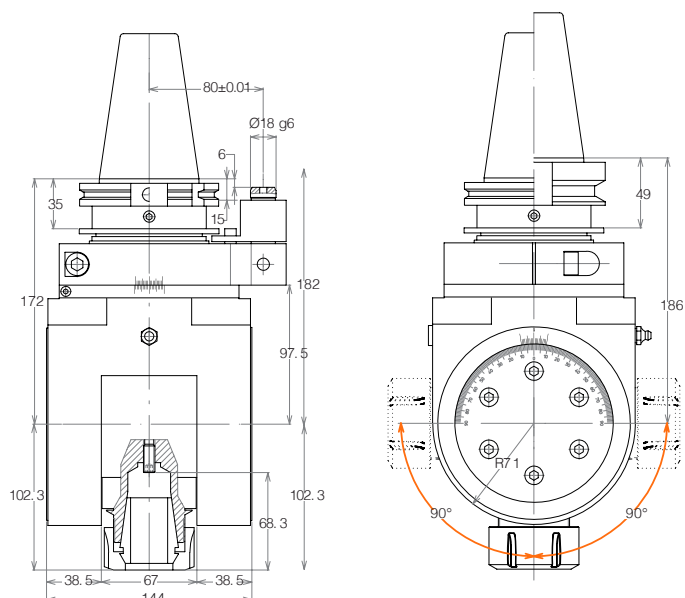

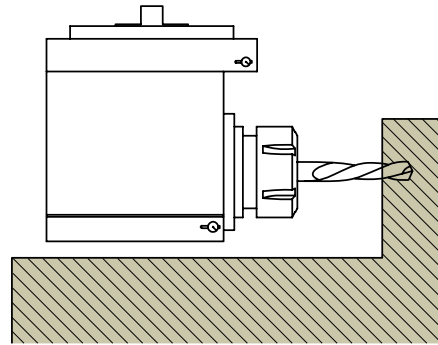

Suitable for all machine types by using a connection kit
 Verwendbar mit allen Maschinentypen mithilfe einer Anschlusschnittstelle

SK30, SK40, SK50, BT30, BT40, BT50, HSK63A, HSK100A
 Transfer Machines / Transferanlagen

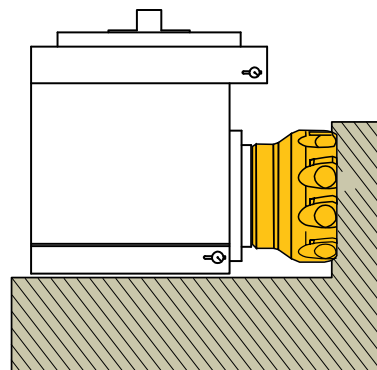

Features

For drilling, tapping and milling operations
 Usable on both CNC and conventional machine tools
 Heat-treated aluminium or steel main body
 Compact and rigid construction

Merkmale

Bohren, Gewindebohren und Fräsen
 Flanschverbindung mit der Spindel;
 manueller Wechsel
 Hauptkörper aus wärmebehandelter
 Aluminium- oder Stahllegierung
 Kompakte und rigide Bauform

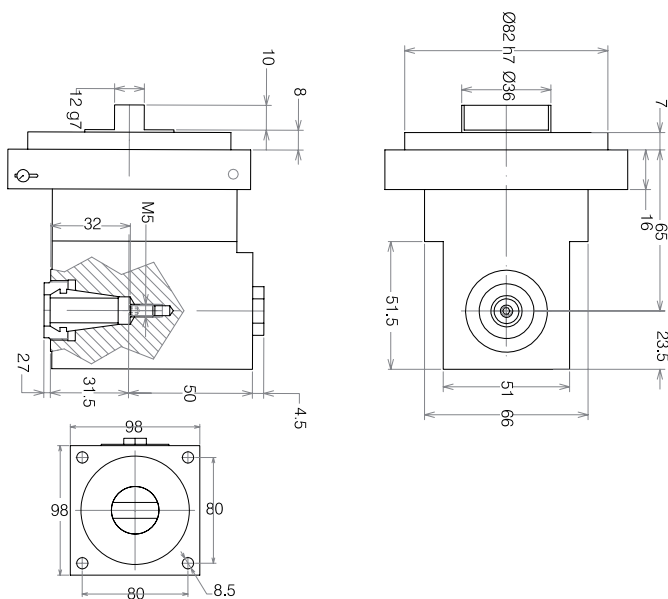

GA-F16-S

ER16	6.000 RPM	3,4 kW
------	-----------	--------

Schubkraft Thrust	Gewicht Weight	Übersetzung Ratio
----------------------	-------------------	----------------------

700 N 2 kg 1:1

Bohren Drilling	$\varnothing 10$
Gewinde Tapping	M8

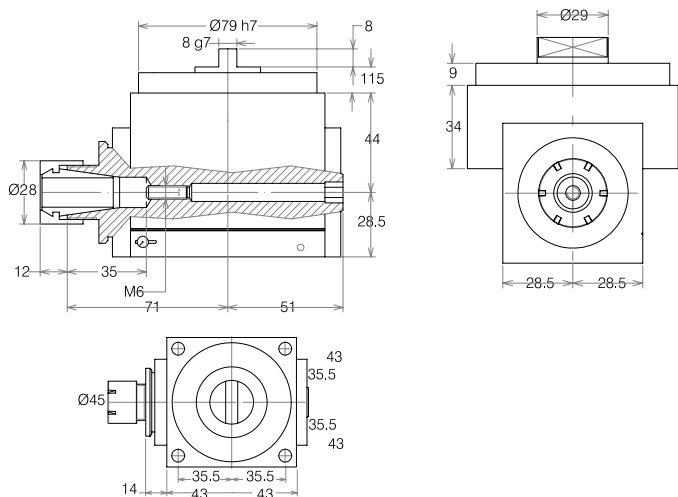
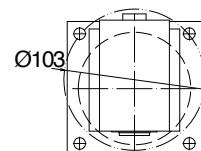

GA-F20

ER20	3.000 RPM	2,5 kW
------	-----------	--------

Schubkraft Thrust	Gewicht Weight	Übersetzung Ratio
----------------------	-------------------	----------------------

1400 N 2,4 kg 1:1

Bohren Drilling	$\varnothing 13$
Gewinde Tapping	M10

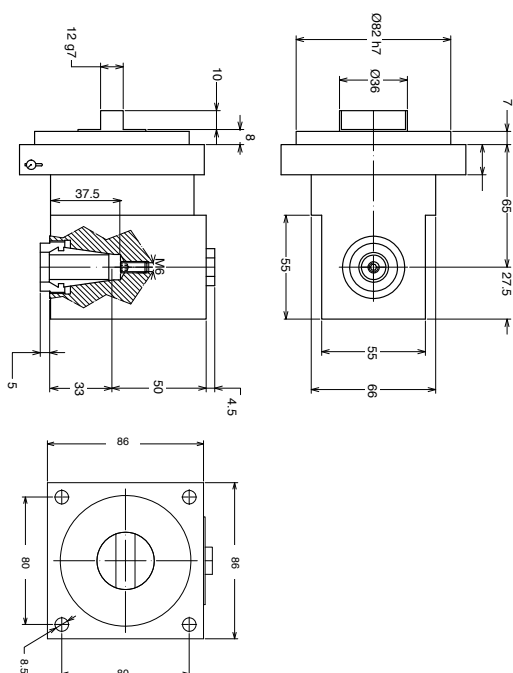
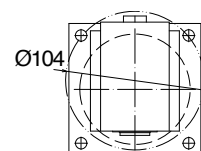

GA-F20-S

ER20	6.000 RPM	3,4 kW
------	-----------	--------

Schubkraft Thrust	Gewicht Weight	Übersetzung Ratio
----------------------	-------------------	----------------------

700 N 2 kg 1:1

Bohren Drilling	$\varnothing 13$
Gewinde Tapping	M10

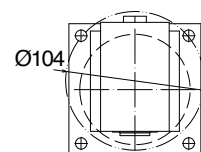

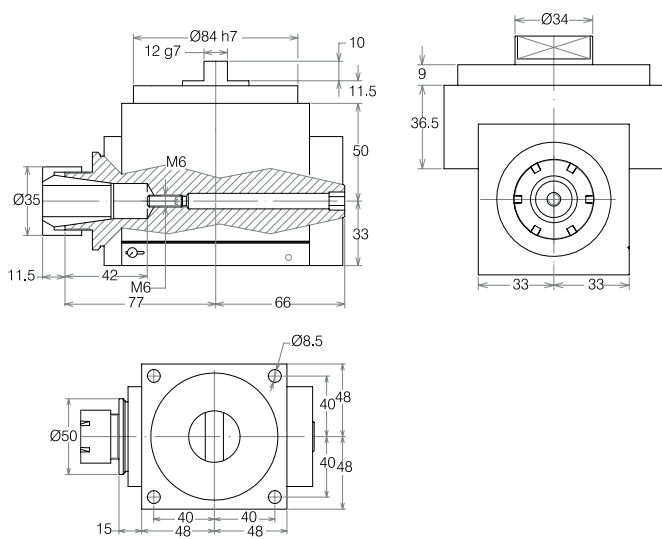

GA-F25

ER25	3.000 RPM	4,2 kW
------	-----------	--------

Schubkraft Thrust	Gewicht Weight	Übersetzung Ratio
1400 N	3 kg	1:1

Bohren Drilling	Ø16
Gewinde Tapping	M12

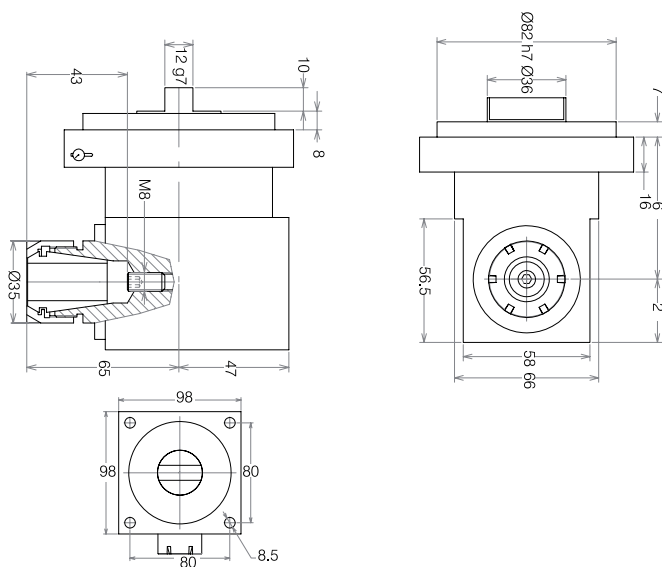

GA-F25-S

ER25	6.000 RPM	3,2 kW
------	-----------	--------

Schubkraft Thrust	Gewicht Weight	Übersetzung Ratio
1000 N	2,3 kg	1:1

Bohren Drilling	Ø16
Gewinde Tapping	M12

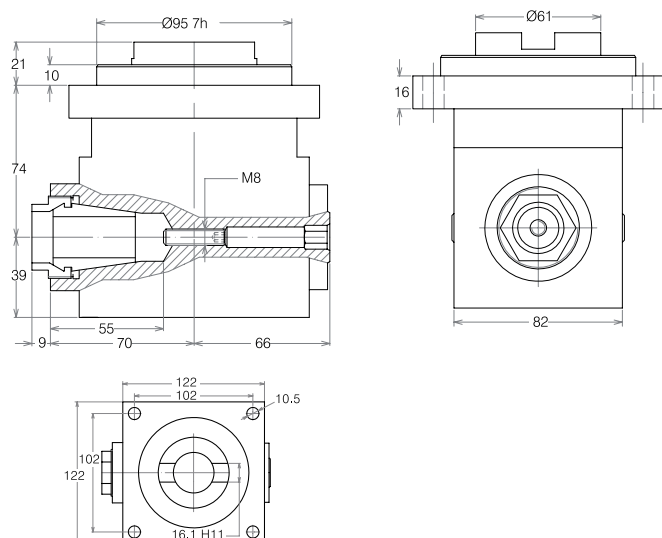
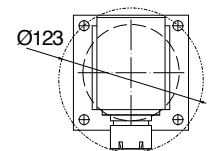

GA-F32

ER32	3.000 RPM	47 Nm
------	-----------	-------

Schubkraft Thrust	Gewicht Weight	Übersetzung Ratio
1500 N	7,7 kg	1:1

Bohren Drilling	Ø20
Gewinde Tapping	M16

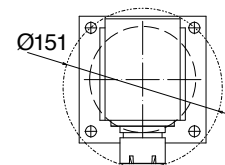

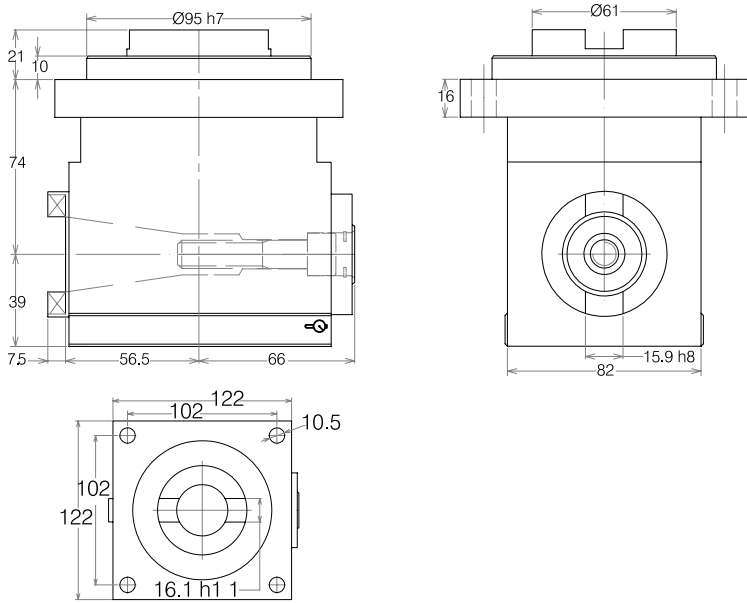

GA-FX30

ISO30	3.000 RPM	4 kW
Schubkraft Thrust	Gewicht Weight	Übersetzung Ratio
1500 N	7,7 kg	1:1
Bohren Drilling	Ø20	
Gewinde Tapping	M16	

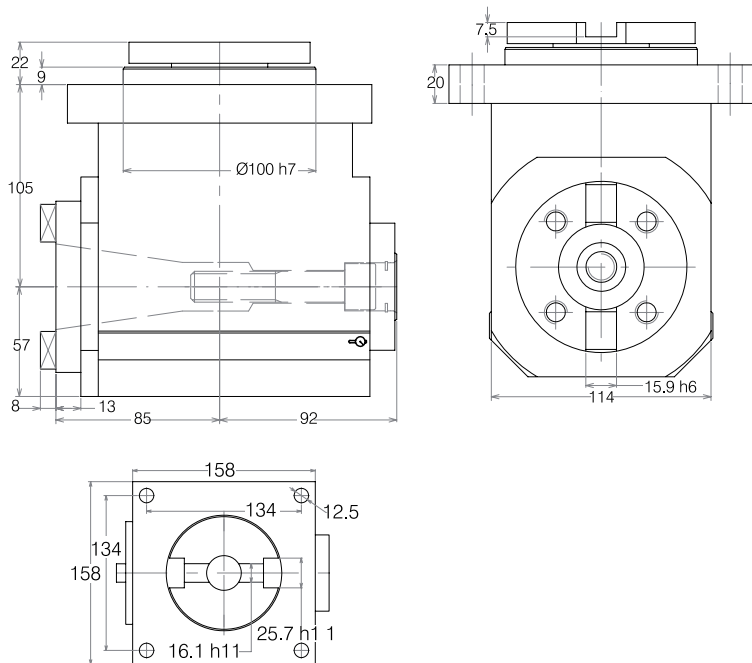

GA-FX40

ISO40	3.000 RPM	105 Nm
Schubkraft Thrust	Gewicht Weight	Übersetzung Ratio
5000 N	22 kg	1,5:1
Bohren Drilling	Ø26	
Gewinde Tapping	M20	

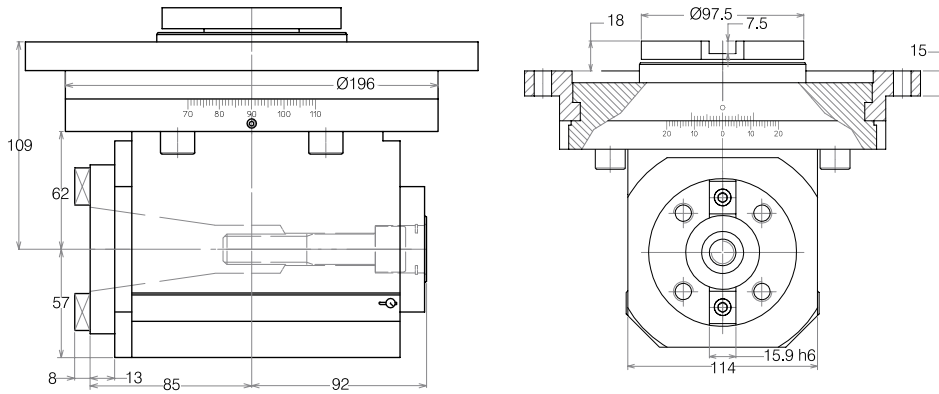

GA-FX40 ROTATE

ISO40	3.000 RPM	105 Nm
Schubkraft Thrust	Gewicht Weight	Übersetzung Ratio
5000 N	26 kg	1,5:1
Bohren Drilling	Gewinde Tapping	
Ø26	M20	

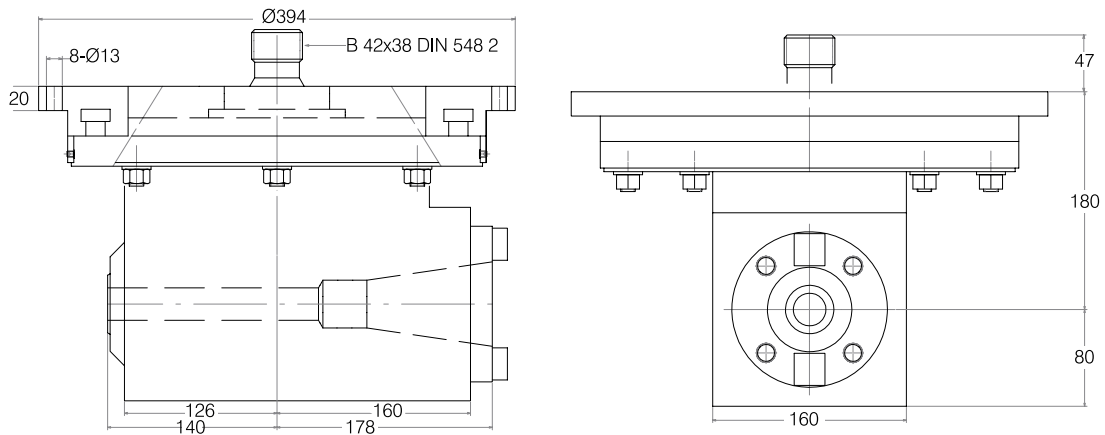

GA-FX50

ISO50	3.000 RPM	340 Nm
Gewicht Weight	Übersetzung Ratio	
40 kg	1:1	
Bohren Drilling	Gewinde Tapping	
Ø45	M36	



Features

For drilling, tapping and milling operations
Used with a flange interface with the spindle for manual loading
Directly clamp a variety of toolholders such as collet chuck, milling chuck, weldon holder, hydraulic chuck.

Versions:

GT-FX40:

SK40, BT40 / HSK63 output spindle

GT-FX50:

SK50, BT50 / HSK100 output spindle

Merkmale

Bohren, Gewindebohren und Fräsen
Flanschverbindung mit der Spindel;
manueller Wechsel
Direkte Spannung von Werkzeughaltern wie Spannzangenfutter, Kraftspannfutter, Weldonaufnahme, Hydrodehnfutter.

Versionen:

GT-FX40:

SK40, BT40 / HSK63 Ausführung

GT-FX50:

SK50, BT50 / HSK100 Ausführung

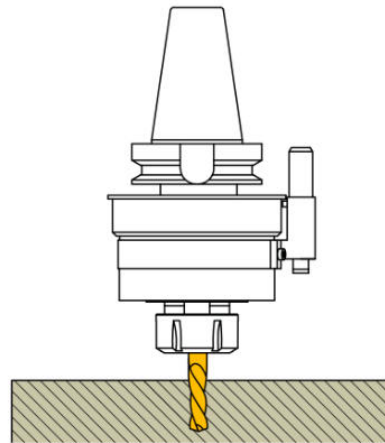

Features

For drilling, light milling operations and for finishing on steel, aluminium, plastic and wood
Interchangeable shank
Usable on both CNC and conventional machine tools
Heat-treated steel alloy main housing
Coolant feed through stop-bar pin

Merkmale

Für Bohrungen, leichte Fräsbearbeitungen und Schlichten von Stahl, Aluminium, Kunststoff und Holz
Wechselbarer Kegelschaft verwendbar mit CNC- und Universalwerkzeugmaschinen
Hauptkörper aus wärmebehandelter Stahllegierung
Kühlmittelzufuhr durch Anschlagstift

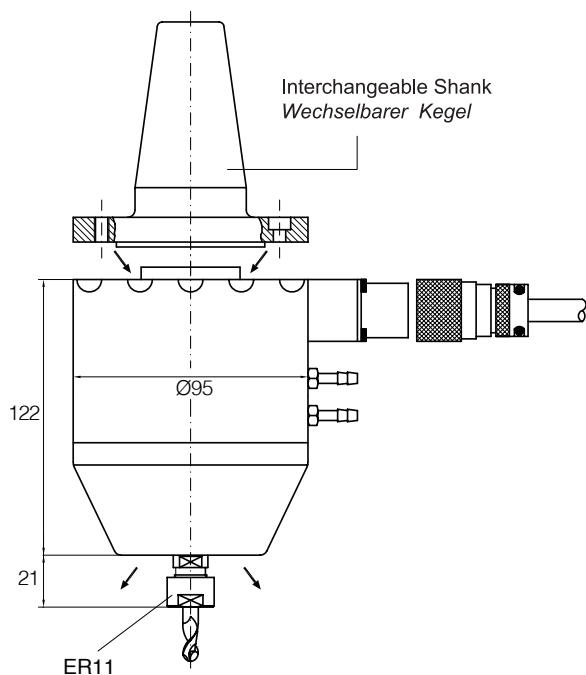

SE-11 electric / elektro

Max. 44.000 RPM Cont. / Dauernd

Max. 60.000 RPM Cont. / Dauernd

SK40 / BT40 / CAT40 / HSK63

SK50 / BT50 / CAT50 / HSK100

ER11 **3,5 Kg**

RPM	44.000	60.000
Hz	750	1.000
KW	1	1,6
Nm	0,2	0,2

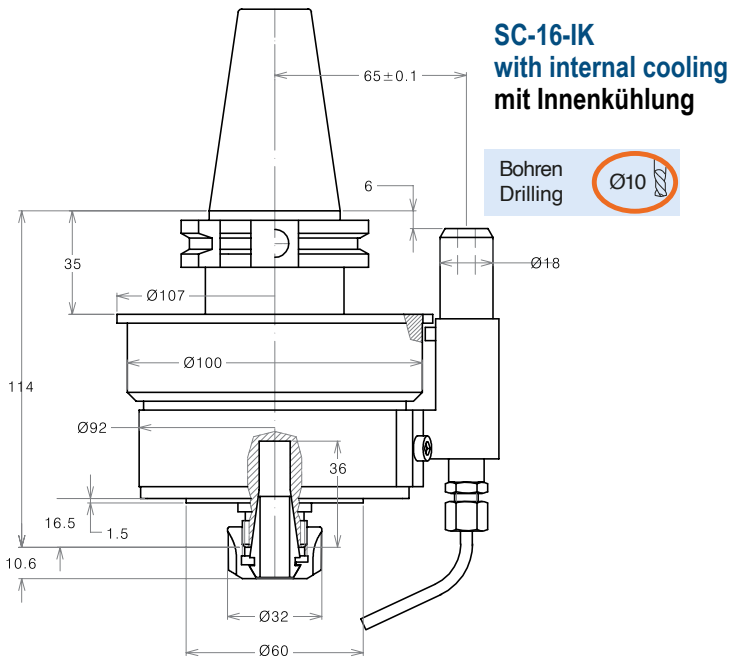

SC-16 ceramic/ keramisch

Max. 30.000 RPM

Max. 24.000 RPM

Cont. / Dauernd

S-16

Max. 24.000 RPM

Max. 19.200 RPM

Cont. / Dauernd

SK40 / BT40 / CAT40 / HSK63

SK50 / BT50 / CAT50 / HSK100 *

ER16	1,7 Kw	
Schubkraft Thrust	Gewicht Weight	Übersetzung Ratio
380 N	3,8 kg * 6,2 kg	1:4,8

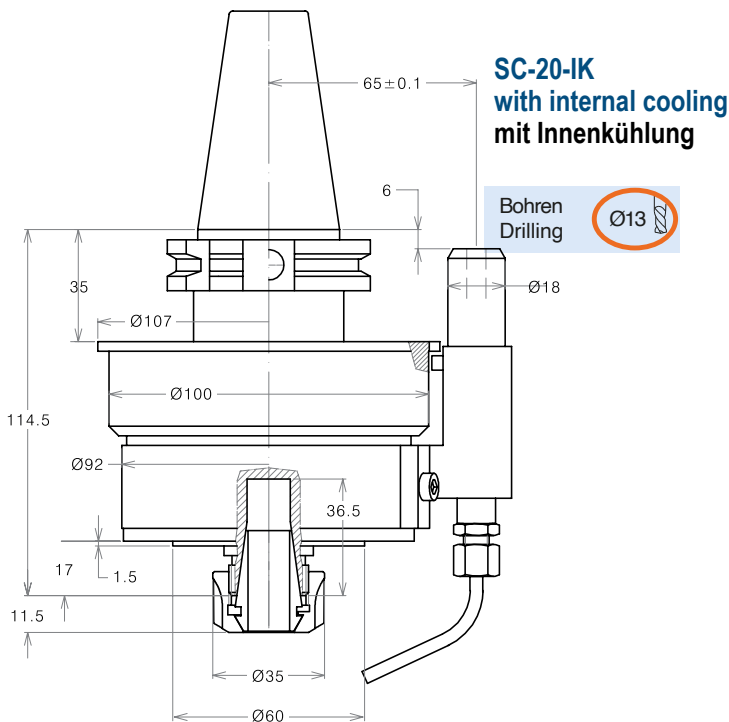

SC-20 ceramic/ keramisch

Max. 24.000 RPM

Max. 19.200 RPM

Cont. / Dauernd

S-20

Max. 19.000 RPM

Max. 15.360 RPM

Cont. / Dauernd

SK40 / BT40 / CAT40 / HSK63

SK50 / BT50 / CAT50 / HSK100 *

ER20	1,7 Kw	
Schubkraft Thrust	Gewicht Weight	Übersetzung Ratio
610 N	4kg * 6,4 kg	1:4,8

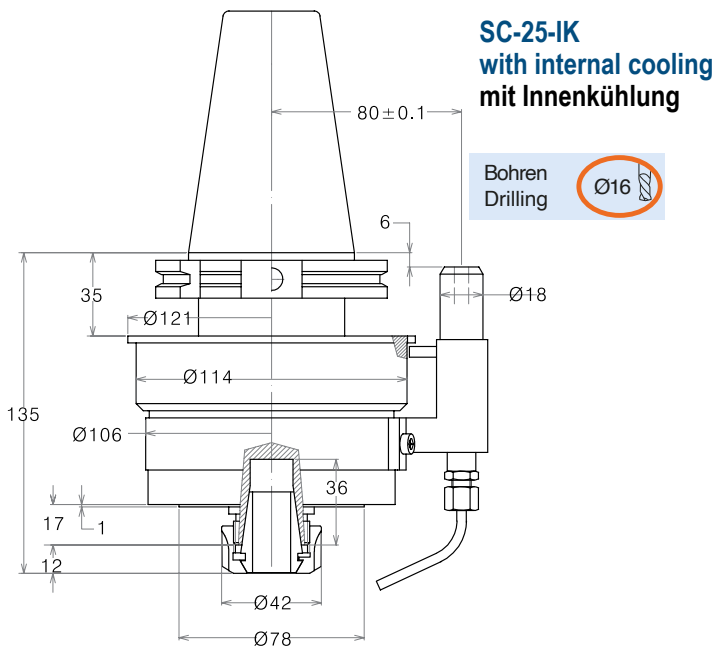

SC-25 ceramic/ keramisch

Max. 18.000 RPM

Max. 15.000 RPM

Cont. / Dauernd

S-25

Max. 15.000 RPM

Max. 12.000 RPM

Cont. / Dauernd

SK50 / BT50 / CAT50 / HSK100

ER25

3,6 Kw

Schubkraft
Thrust

Gewicht
Weight

Übersetzung
Ratio

630 N

8 kg

1:4,8

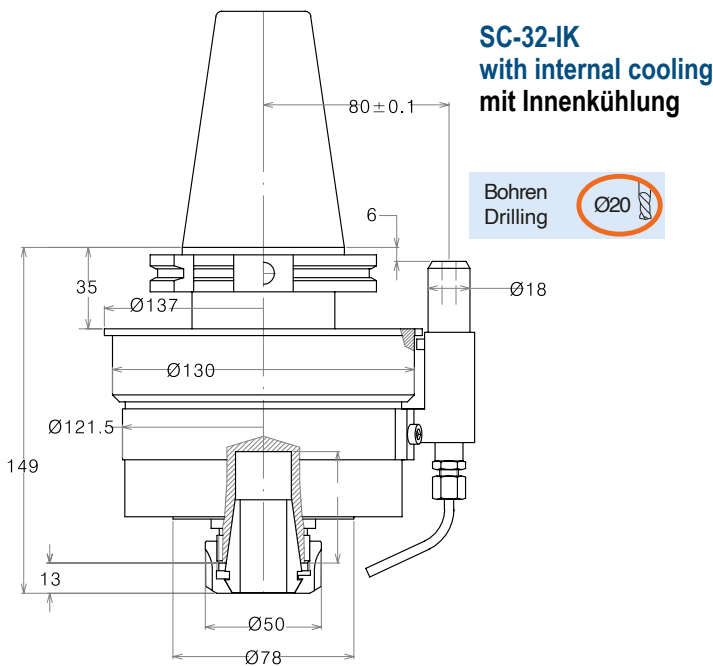

SC-32 ceramic/ keramisch

Max. 12.000 RPM

Cont. / Dauernd

S-32

Max. 9.600 RPM

Cont. / Dauernd

SK50 / BT50 / CAT50 / HSK100

ER32

4,4 Kw

Schubkraft
Thrust

Gewicht
Weight

Übersetzung
Ratio

900 N

8 kg

1:4,8

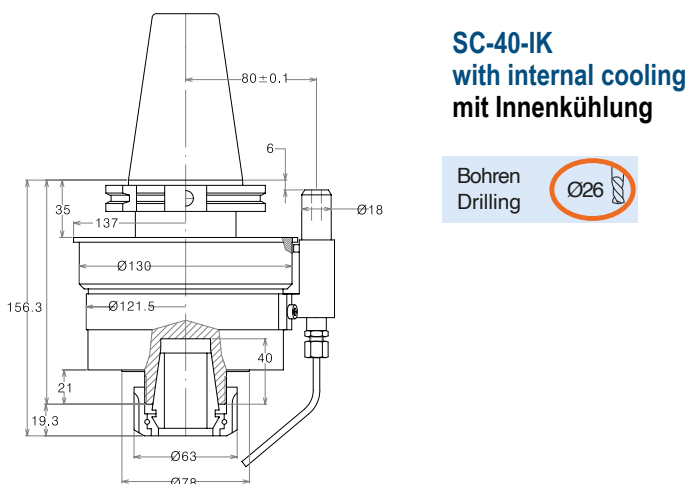

S-40

SK50 / BT50 / CAT50 / HSK100

ER40

9,600 RPM

4,4 Kw

Schubkraft
Thrust

Gewicht
Weight

Übersetzung
Ratio

1100 N

9,6 kg

1:4,8

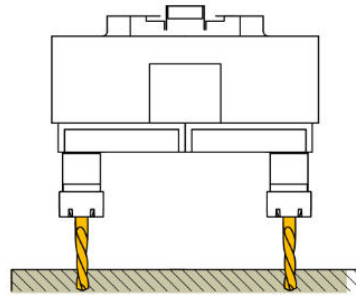

Features

Drilling, tapping and countersinking
 Usable on conventional machines and drill presses by using a connection kit
 Heat-treated aluminium alloy main housing
 Compact and lightweight construction

Merkmale

Bohren, Gewindebohren und Senken
 Verwendbar mit
 Universalwerkzeugmaschinen und
 Standbohrern
 Hauptgehäuse aus wärmebehandelter
 Aluminiumlegierung
 Kompakt und leicht

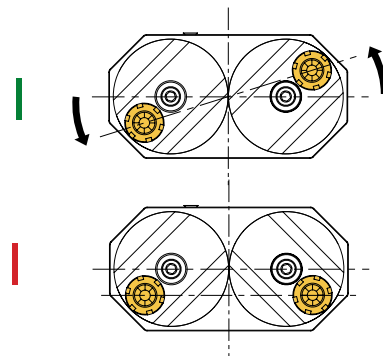
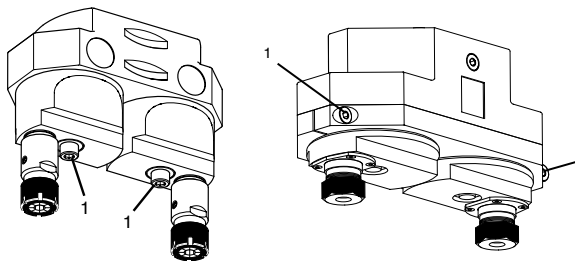

How to Use

To set up the centre distance between the spindles, unscrew screw 1 of each spindle unit and rotate them in the same direction, until the required distance is obtained.
 In order to balance the forces during machining operation, position the spindles as shown in the figure.
 At the end of this operation fasten screw 1 of each spindle unit using a torque wrench.

Einsatz

Um den passenden Abstand zwischen den Spindeln einzustellen, lockern Sie die Schraube 1 von jeder Spindeleinheit und drehen Sie diese in dieselbe Richtung, bis der gewünschte Abstand erreicht ist.
 Um während der Verarbeitungsprozesse die Kraft auszugleichen, stellen Sie die Spindeln ein, wie auf dem Bild.
 Anschließend klemmen Sie Schraube 1 jeder Spindel mittels Drehmomentschlüssels.

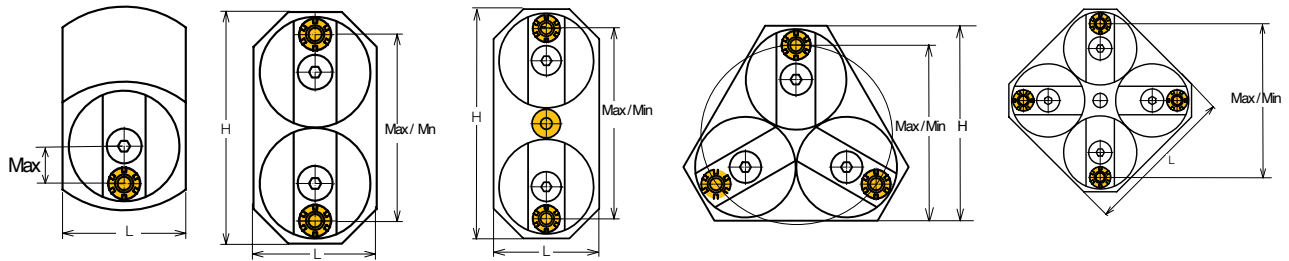

Code	ER	Min	Max	H	L	RPM	Kw	N	Ratio	kg
MS8-1	ER8	0	28	-	46	3500	0,18	195	1:1	0,5
MS8-2	ER8	13,5	69,5	87	46					0,9
MS8-3L	ER8	27	83	100	46					1
MS8-3	ER8	19,9	75,9	80	-					1,3
MS8-4	ER8	30,7	86,7	85	-	1750			1:2	1,8
MS11-1	ER11	0	56	-	80	3000	0,34	490	1:1	1,8
MS11-2	ER11	18	130	154	80					2,4
MS11-3L	ER11	36	148	173	80					2,8
MS11-3	ER11	29,5	141,5	144,5	-					3,5
MS11-4	ER11	49	161	154	0				1:2	4,6
MS16-1	ER16	0	50	-	80	3000	0,56	735	1:1	3,3
MS16-2	ER16	24	124	154	80					3,3
MS16-2W	ER16	106,25	206,25	264	108					6
MS16-3L	ER16	48,5	148,5	178,5	80					3,6
MS16-3	ER16	35,5	135,5	144,5	-					4,9
MS16-4	ER16	55	155	185	-					6,6
MS-16-4W	ER16	139	239	306,9	162,5					-
MS20-1	ER20	0	53	-	88	3000	1,5	1500	1:1	2,5
MS20-2	ER20	29	135	170	88					3,6
MS20-3L	ER20	63	169	204	88					4,9
MS20-3	ER20	42	148	159,5	-					5,5
MS20-4	ER20	63	169	170	-					7,5
MS25-1	ER25	0	64	-	124	2500	1,1	1135	1:1	4,4
MS25-2	ER25	37	165	212	111					6,3
MS25-3L	ER25	79	207	254	111					7,7
MS25-3	ER25	53	181	199	-					9,2
MS25-4	ER25	79	207	212	-					12,2

- MS: Drilling, tapping / Bohren, Gewindebohren
- MS-W: Drilling, tapping at a wider distance / Bohren, Gewindebohren mit hohem Abstand

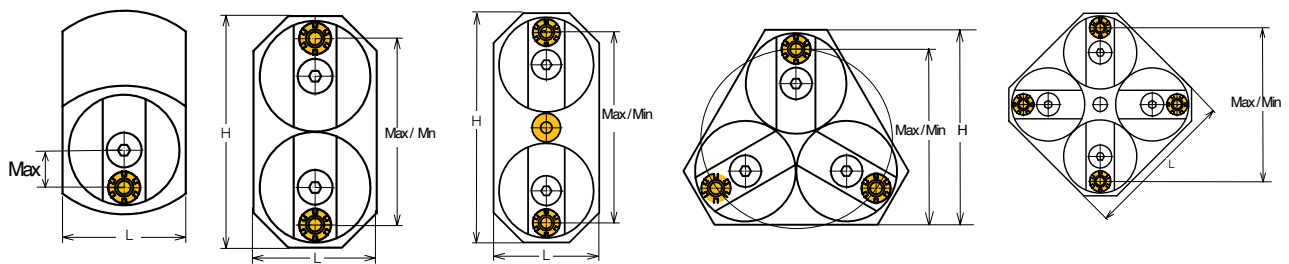

Code	ER	Min	Max	H	L	RPM	Kw	N	Ratio	kg
MF20-2	ER20	37,5	169,5	236	124	2000	2	1000	1:1	9,5
MF25-2	ER25	45	201	278	140	2000	2,5	1500	1:1	13,7

MF: Milling, drilling, tapping / Fräsen, Bohren, Gewindebohren

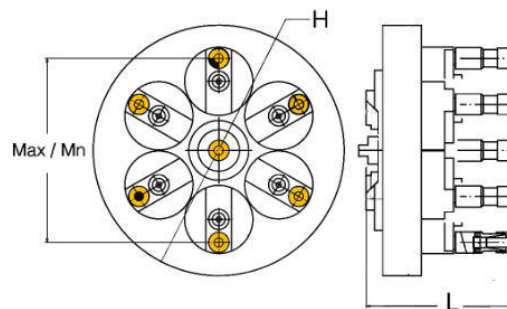

Code	ER	Min	Max	H	L	RPM	Kw	N	Ratio	kg
MS8-7	ER8	56	112	148	104,1	3500	0,18	195	1:1	-
MS11-7	ER11	94	206	272	150,5	3000	0,34	490	1:1	-
MS16-7	ER16	100	200	272	167,5	3000	0,56	753	1:1	-

MS: Drilling, tapping / Bohren, Gewindebohren

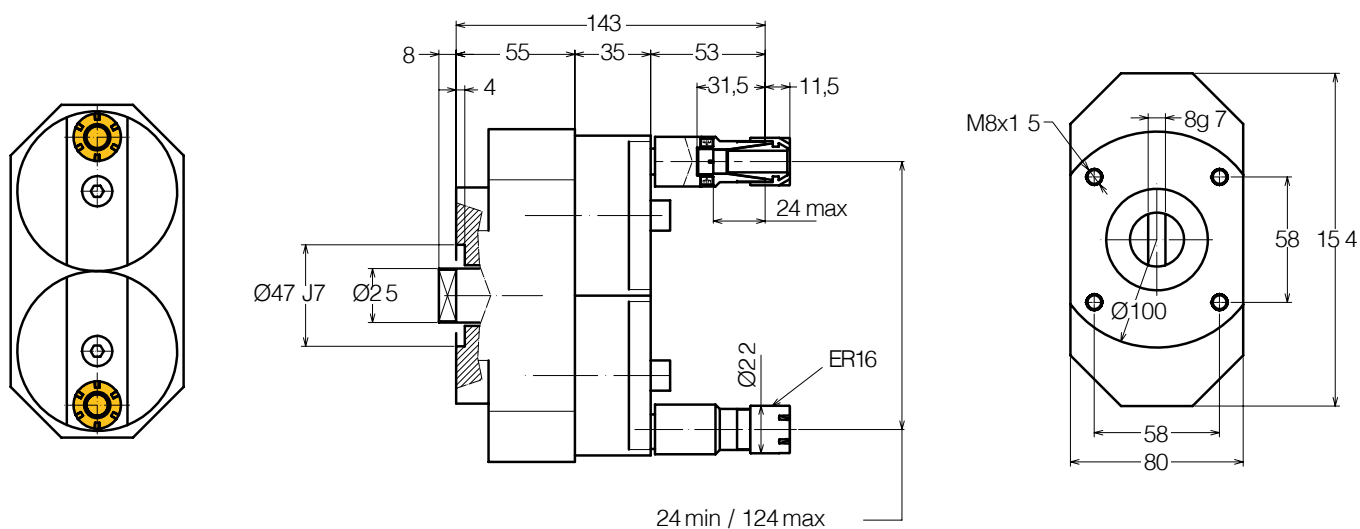

How to Connect to a Machine Maschinenverbindung

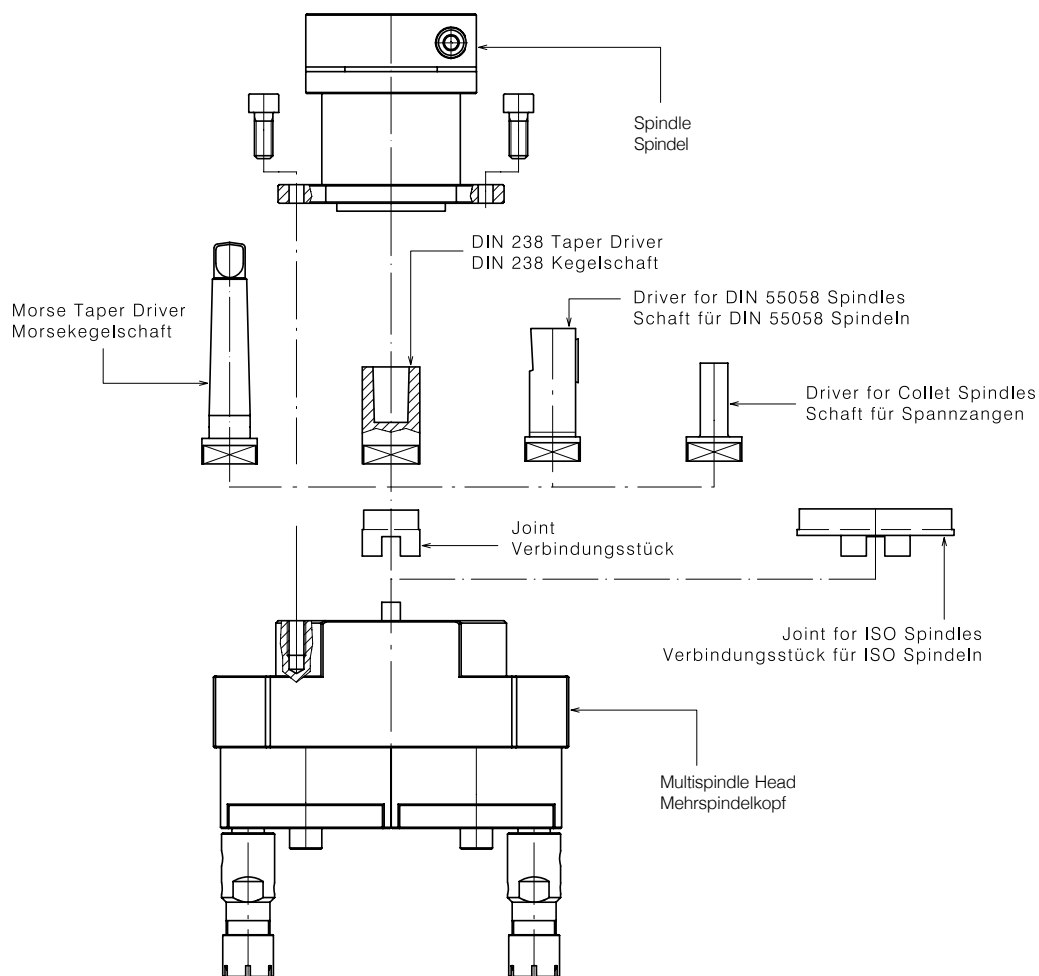

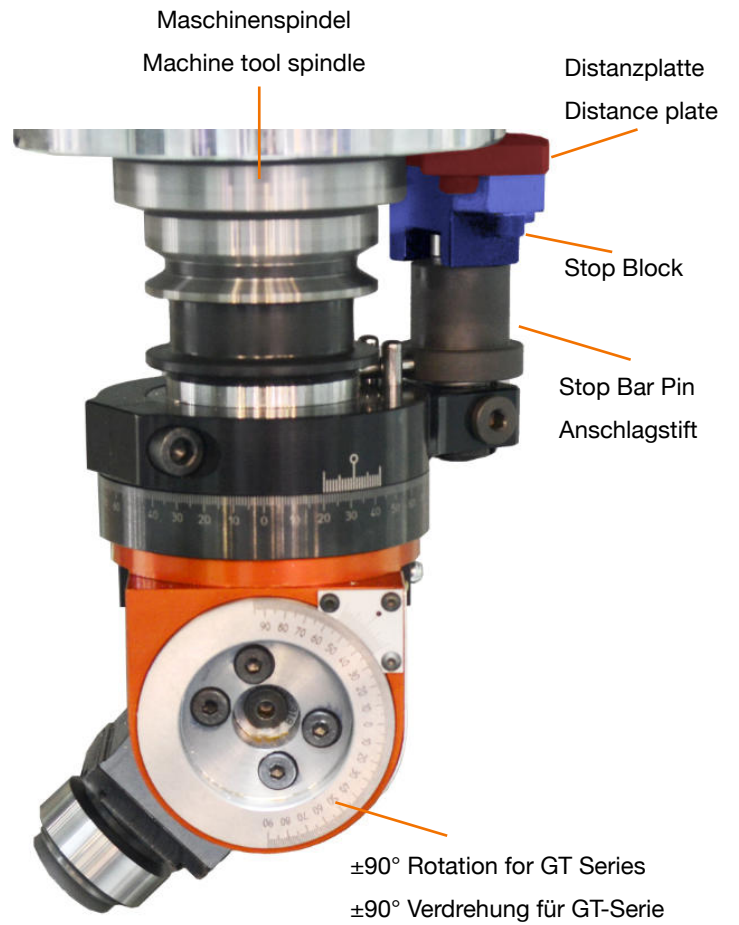

Conical Stop Bar Pin
Konischer Anschlagstift



HSK63 Output
HSK63 Abtrieb

Pick-up Station for GA-X
Aufnahmevorrichtung für GA-X

Pick-up Station for GA-X
Aufnahmevorrichtung für GA-X

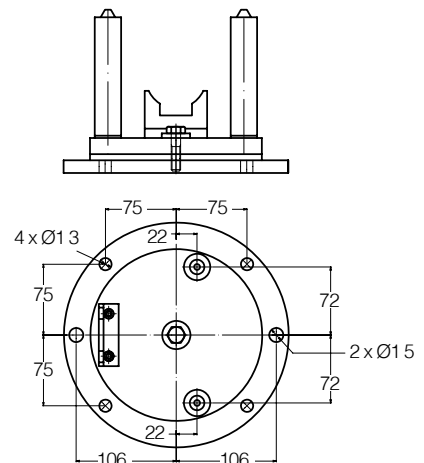

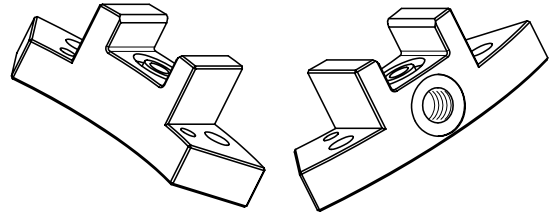
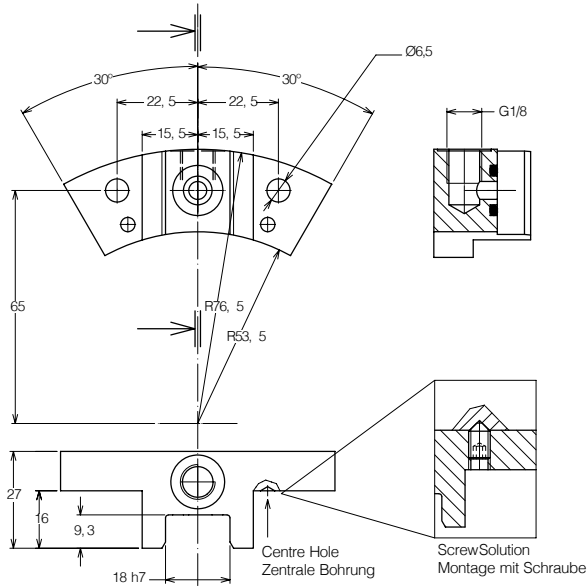

Angle heads are supplied optionally with a standard stop block or a custom-made stop block to be installed on the spindle nose:

Check H Dimension

Using the formula $H - A = P$ calculate plate height (P)

- if $P < 5$ make the height of supplied plate smaller
- if $P > 5$ produce and use a thicker plate

Mount the stop block and the plate if necessary to the spindle nose on the opposite side of the ATC arm

Winkelköpfe werden optional mit einem Standard-Stop-Block oder einem maßgefertigten Stop-Block geliefert, der an die Spindelnase montiert wird:

Maß H kalkulieren

Mit der Formel $H - A = P$ Plattenhöhe (P) ausrechnen

- wenn $P < 5$, gelieferte Platte dementsprechend abschleifen
- wenn $P > 5$, eine höhere Platte fertigen und einsetzen

Stop-Block und wenn nötig die Platte an die Spindelnase gegenüber automatischen Werkzeugwechslers montieren

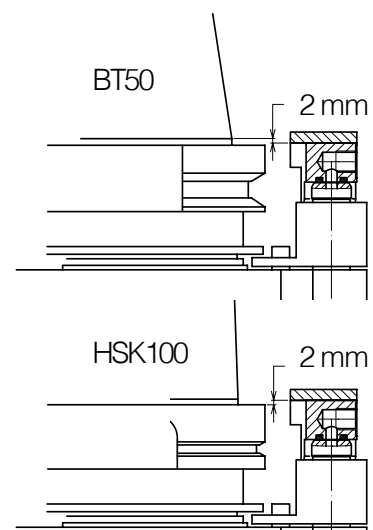
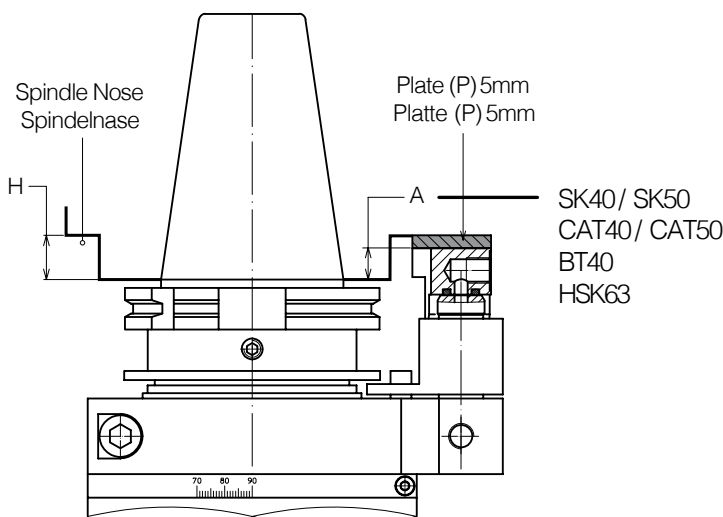

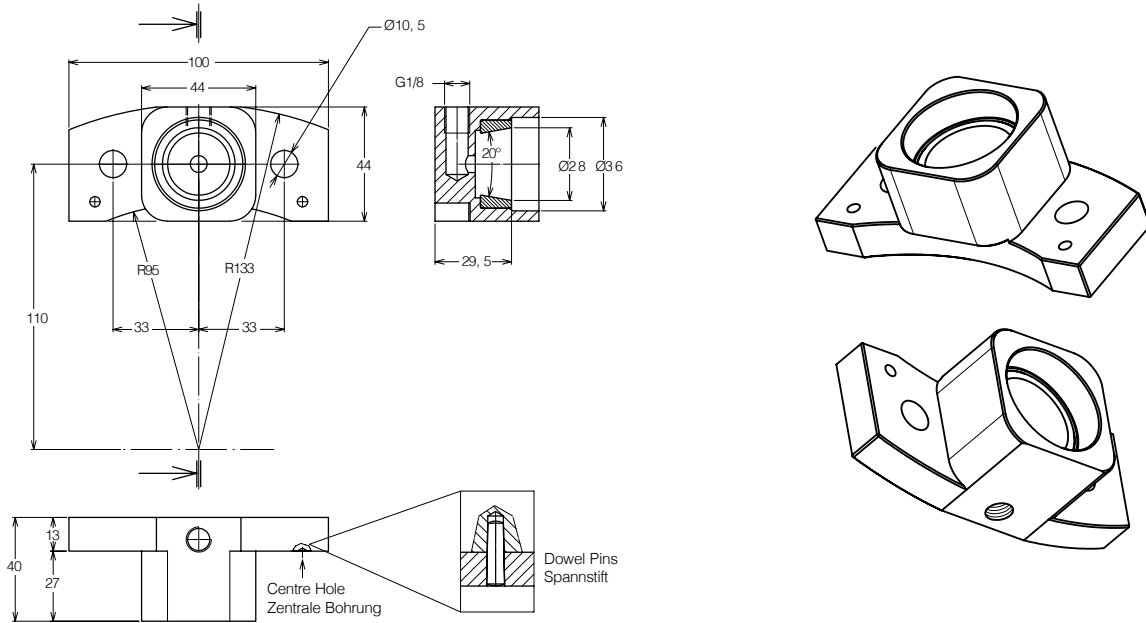

Angle heads are supplied optionally with a standard stop block or a custom-made stop block to be installed on the spindle nose:

Check H Dimension

Using the formula $H - A = P$ calculate plate height (P)

- if $P < 5$ make the height of supplied plate smaller
- if $P > 5$ produce and use a thicker plate

Mount the stop block and the plate if necessary to the spindle nose on the opposite side of the ATC arm

Winkelköpfe werden optional mit einem Standard-Stop-Block oder einem maßgefertigten Stop-Block geliefert, der an die Spindelnase montiert wird:

Maß H kalkulieren

Mit der Formel $H - A = P$ Plattenhöhe (P) ausrechnen

- wenn $P < 5$, gelieferte Platte dementsprechend abschleifen
- wenn $P > 5$, eine höhere Platte fertigen und einsetzen

Stop-Block und wenn nötig die Platte an die Spindelnase gegenüber automatischen Werkzeugwechslers montieren

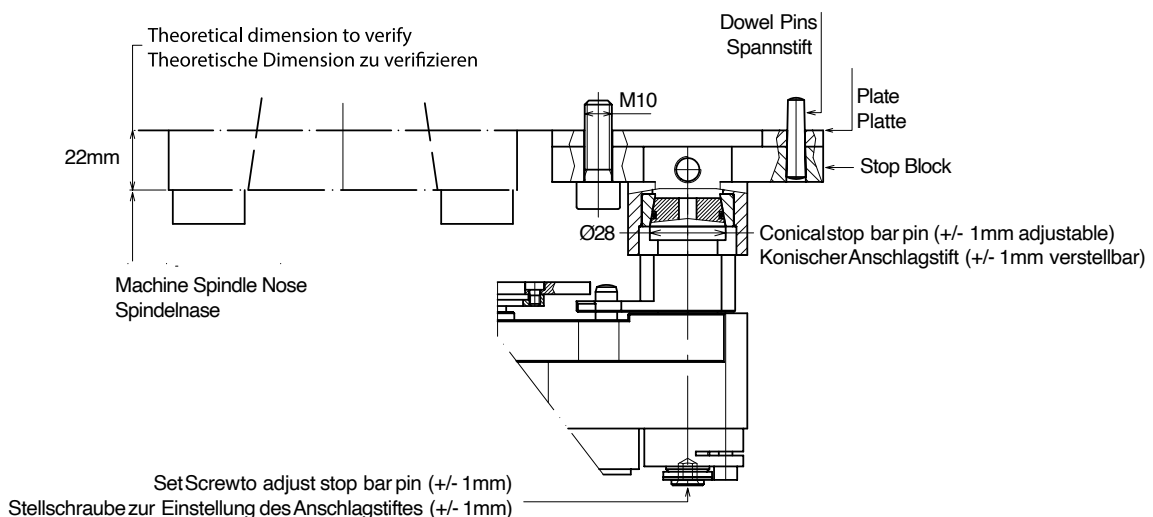



Gisstec GmbH

Ackerstr. 20
40233 Düsseldorf
Germany

+49 211 2486 3666

info@gisstec.com

www.gisstec.com

shop.gisstec.com