



Ortsfeste Spannsysteme | Stationary clamping systems

# PSP...S, PSP...S/AS-i



## Anwendung

Das elektromechanische Schnellspannsystem PSP...S ist zum Spannen von Werkzeugen an Pressenstößeln und Blechhaltern ausgelegt.

## Konstruktionsmerkmale

Die den werkzeugseitigen Spannbolzen umfassenden Spannklaue schwenken beim Lösen radial aus.

Alternativ steht die busgesteuerte Version PSP...S/AS-i mit AS-Interface zur Verfügung.

## Application

The electromechanical clamping system PSP...S is designed for clamping dies on press slides and blankholders.

## Design features

When unclamping the collet opens in order to disengage the draw bolt of the die.

The bus controlled version PSP...S/AS-i with AS-Interface is available as an alternative.

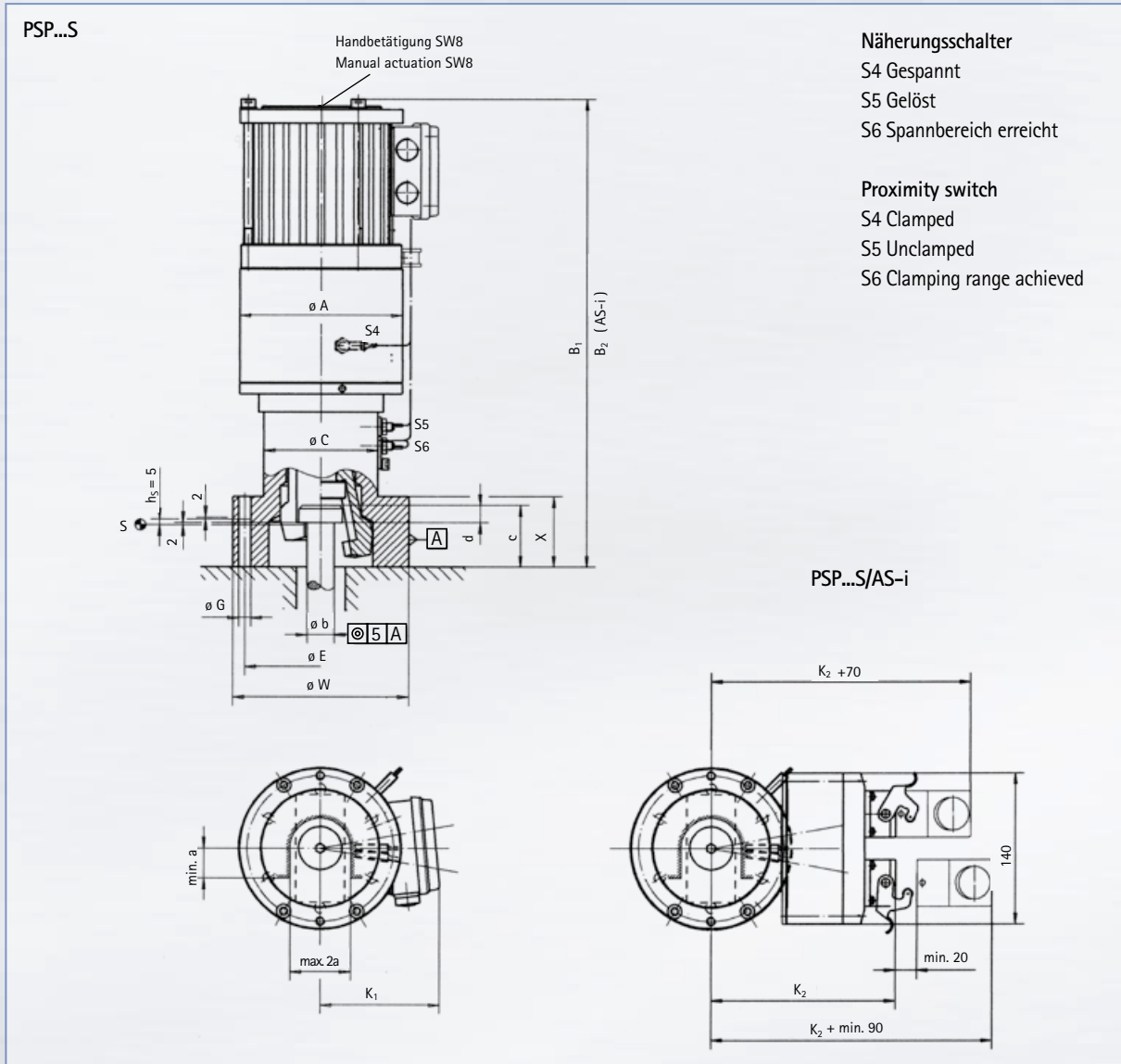

## Mae | Dimensions

| TYP   TYPE      | A   | B <sub>1</sub> | B <sub>2</sub> | C   | E <sub>±0.3</sub> | G <sub>6x60°</sub> | K <sub>1</sub> | K <sub>2</sub> | W   | X  | a  | b  | c  | d  |
|-----------------|-----|----------------|----------------|-----|-------------------|--------------------|----------------|----------------|-----|----|----|----|----|----|
| PSP 170 S/AS-i  | 150 | 432            | -              | 110 | 130               | 14                 | 110            | -              | 150 | 40 | 40 | 25 | 57 | 16 |
| PSP 1120 S/AS-i | 178 | 510            | -              | 128 | 150               | 14                 | 135            | -              | 172 | 78 | 50 | 32 | 68 | 20 |

## Technische Daten | Technical data

| TYP   TYPE      | F <sub>S</sub><br>kN | F <sub>B</sub><br>kN | v<br>mm/s | l<br>A | P<br>kW | % ED | U<br>V | f<br>Hz | m<br>kg |
|-----------------|----------------------|----------------------|-----------|--------|---------|------|--------|---------|---------|
| PSP 140 S/AS-i  | 40                   | 65                   | 1,8       | 1,2    | 0,25    | 15   | 400    | 50      | 24      |
| PSP 170 S/AS-i  | 70                   | 110                  | 5,0       | 3,5    | 1,10    | 15   | 400    | 50      | 33      |
| PSP 1120 S/AS-i | 120                  | 190                  | 4,5       | 7,2    | 2,20    | 15   | 400    | 50      | 45      |